



THE DISTRICT BOARD OF TRUSTEES OF GULF COAST STATE COLLEGE

**REQUEST FOR PROPOSALS (RFP) FOR GULF COAST STATE COLLEGE
STUDENT UNION EAST (SUE) DESIGN-BUILD ROOF PROJECT**

**OFFICE OF THE PROCUREMENT DIRECTOR
5230 West U.S Highway 98
Room 126
PANAMA CITY, FLORIDA 32401**

SUBMITTED BY:

TABLE OF CONTENTS

Advertisement for Proposals	3
Instruction to Proposers	4 – 9
Submittal/Evaluation Information	10 – 11
Project Scope and Goals	12 - 15
Risk Management Requirements	16 – 20
Addendum Acknowledgement Form	21
Anti-Collusion Clause Form	22
Conflict of Interest Form	23
Drug Free Workplace Form	24
E-Verify Form	25
Public Entity Crime Form (PUR7068)	26 - 27
Sub-Contractors Form	28
Labor and Material Payment Bond	29
Performance Bond	30
Proposals Form	31
RFP Schedule	32
Exhibit “A” - Photo of Existing Roof	33 -34
Exhibit “B” – Plans of existing Building	35 – 56

**THE DISTRICT BOARD OF TRUSTEES OF
GULF COAST STATE COLLEGE
NOTICE OF REQUEST FOR PROPOSALS**

SEALED REQUESTS FOR PROPOSALS (RFP) from qualified firms to provide Design-build Roof Services for Gulf Coast State College, shall be received by the **DISTRICT BOARD OF TRUSTEES OF GULF COAST STATE COLLEGE** at the Procurement Department, 5230 West U.S Highway 98, Panama City, Florida 32401 up until **2:00 PM (CST) on Thursday, December 01, 2016**. Sealed submittals shall be opened at **2:00pm (CST) on Thursday, December 01, 2016**. **There will be a pre-proposal meeting and roof walk-through at 9:00AM (CST) on Monday, November 07, 2016** at Gulf Coast State College Main Campus Student Union East.

Request for Proposals shall be submitted in a sealed envelope, plainly marked with respondent's name, address, date and time of opening, and RFP number RFP#2-2016/2017 for Gulf Coast State College Student Union East Design-build Roof Project.

Please submit one (1) original (Marked Original), Three (3) copies and one (1) readable CD or electronic thumb drive of your proposal package to Gulf Coast State College Procurement Office.

Description of Work: This is an advertisement for proposals, for Design-build services of a new roof on Student Union East Building located on Gulf Coast State College main campus.

RFP NO: 2-2016/2017

RFP documents may be obtained at the Gulf Coast State College Procurement Department, 5230 West U.S Highway 98, Panama City, FL 32401. Electronic versions of the proposal package are available via internet at: <http://www.gulfcoast.edu/administration-departments/index.html> Inquiries regarding this RFP should be directed to Fred Brown, Procurement Director, via email to: fbrown3@gulfcoast.edu or FAX to (850) 767 8043.

The District Board of Trustees of Gulf Coast State College reserves the right to accept or reject any and all proposals in whole or in part, to withdraw the RFP, to waive informalities in the solicitation documents, to obtain new proposals, or to postpone the opening pursuant to the Gulf Coast State College Procurement Policy. Each proposal shall be valid and binding for a period of ninety (90) days after the opening.

Gulf Coast State College is an Equal Opportunity Employer.

Submitted by Brenda Washington
Senior Purchasing Assistant/Buyer
bwashington@gulfcoast

NOTICE TO PUBLISHER: This legal ad to appear on Sunday, October 30, & November 06, 2016

Please forward the original "Proof of Publication" and the invoice to:
Gulf Coast State College, 5230 West Highway 98
Attn: Accounts Payable; Email: accpay@gulfcoast.edu
Panama City, Florida 32401

Purchase Order Number P_____ will be forwarded to you

INSTRUCTIONS TO PROPOSERS

1. Proposal Documents

The solicitation documents are on file at the Gulf Coast State College Procurement Department, and available on its website: <http://gulfcoast.edu/administration-departments/procurement/index.html>.

It is the intent of this Request for Proposals (RFP) to solicit proposals from interested and qualify Firms that are capable of performing services.

2. Questions Regarding RFP:

Proposers shall direct any questions regarding this RFP in writing to the GCSC Procurement Director, Fred Brown, at fbrown3@gulfcoast.edu. All questions shall be submitted before **4:00 pm on Wednesday, November 16, 2016.**

GCSC will respond in writing to any questions regarding the RFP submitted in writing prior to the deadline identified above. Such responses will be issued as an addendum to this Request for Proposals. All addendums issued are the sole responsibility of firms.

No telephone, verbal or oral questions will be accepted and no oral statement made by any officers, employee or agent of GCSC shall be binding. Only statements in writing in this RFP or in any addendum to this RFP shall be binding on GCSC.

3. Proposal Form

All proposals shall include completed copies of the forms provided in this RFP, properly executed and with all items completed. Do not change the wording of the Proposal Form and do not add words to the wording of the Proposal Form. No conditions, limitations or provisions will be attached or added to the Proposal Form by the Proposer. Alterations by erasure or interlineations must be explained or noted in the proposal over the signature of the proposer.

4. Proposal Submittal Requirements

All proposers and all proposed subcontractors shall have the following certifications and qualifications.

- 1. State of Florida Business License**
- 2. State of Florida License Engineering/Architect/Contractor**
- 3. Provide Proof of Insurance for the State of Florida**
- 4. All individual Florida professional licenses required by law for those individuals who are proposed to provide work on this project being procured pursuant to this RFQ.**

Each Proposer being considered for this project is required to submit a Statement of Qualifications (SOQ). The SOQ shall include sufficient information to enable the GCSC to evaluate the qualifications of the Proposer to provide the desired services.

All submittals are to be on 8 ½” x 11” papers or if larger documents are required they are to be folded to 8 ½” x 11” sizes. Proposals should be stapled together or bound with comb binding. Proposals submitted in 3 ring binders **will not** be accepted. Submit one (1) original (plainly marked “ORIGINAL”), three (3) copies and one (1) readable CD or electronic thumb drive to:

**Gulf Coast State College Procurement Department
5230 West U.S Highway 98, Room 126
Panama City, Florida 32401**

The Proposer must have a minimum of five (5) years’ experience designing roofs, preferably retrofit roofs, and performing construction services required herein and submittals shall include the following items in the order listed:

- a. SF 330 – for Architect/Engineering Firm and all sub consultants/contractors. The SF 330 Section E shall only include personnel that will be working on the project. Section F “Example Projects Which Best Illustrate Proposed Team’s Qualifications For This Contract” shall only include similar project(s).
- b. Business, Architect, Engineering, Contractor firm and professional licenses for all the proposer and team members to include proposed sub consultants, as required by law.
- c. Project Organization Chart. The chart shall only include personnel that will work on this project. The Architect/Engineering firm in charge of the project design shall be clearly indicated along with all team members supervised by this individual.
 - Project Organization Chart to include names, titles, work telephone numbers and work addresses
- d. Approach and understanding of the project. This should be a narrative description and any applicable illustrations to show that the firm understands all elements of the project, to include but not limited to: site conditions, building basic configuration, space usage, desired aesthetics, project coordination responsibilities, permitting, total quality control of design, design submittal to include specifications and construction sequence, etc. Narrative shall also discuss the firm’s experience with working with colleges.
- e. Change order history showing dollar amounts and time extensions over past three (3) calendar years.
- f. Brief history of firm’s sales/services operations in the local area and accounts with school districts, colleges and universities in the State of Florida. Recent, current and projected workload and ability to incorporate this project into workload.
- g. Project Schedule, schedule shall be based on calendar days. Proposer shall designate the amount of calendar day after Notice to Proceed.
- h. Description of firm’s experience in providing similar size account services. Names, addresses, and telephone numbers of at least three (3) references with similar sized accounts or larger must be provided. If the Proposer doesn’t

possess any experience similar to the services required, the proposer must provide any pertinent information or experiences that may qualify it for consideration of award.

- i. Proposer shall provide a single point of contact for matters in relation to the proposal and understand award of this proposal shall require a single point of contact for services.
 - Name
 - Phone Number(s)
 - Email Address
- j. Information regarding whether the Proposer is a certified minority business enterprise.
- k. Addendum Acknowledgement Form
- l. Anti-Collusion Clause Form
- m. Conflict of Interest Form
- n. Drug Free Workplace Form
- o. E-verify Form
- p. PUR 7068 Public Entity Crime Form
- q. Sub-Contractors Form
- r. Labor and Material Payment Bond
- s. Performance Bond

The Proposer may not change or alter proposal, or work as detailed at any time after submittal opening from what was presented in their RFP unless approved by the GCSC.

5. Delivery

Each proposal package shall be addressed to the District Board of Trustees of Gulf Coast State College, Attn: Procurement, and shall be delivered to the Gulf Coast State College, at 5230 West U.S Highway 98, Room 121 or 126, Panama City, Florida 32401, on or before the day and/or hour set for the opening of proposals. Each proposal shall be enclosed in a sealed envelope bearing the title of the work, the name of the proposer and the date for opening. It is the sole responsibility of the proposer to ensure that their proposal submittal is received on time. Late submissions will be rejected.

6. Withdrawal of Proposals

Any proposer may withdraw its proposal by written request, to GCSC Procurement Director at any time prior to the deadline for proposal.

7. Basis of Award

GCSC will select firm based on the highest score per Evaluation Form. **Firm deemed to be the most highly qualified to perform the required services under this RFP and provides the highest total value.** Selection of firm will be based on the criteria form shown in RFP#2 -2016/2017. GCSC will then negotiate a contract with the most qualified firm for a professional service at compensation which GCSC determines is fair, competitive and reasonable, after the District of Board of Trustees approval.

8. Right to Reject

The College reserves the right, and the College's Director of Procurement, has sole discretion, to cancel a solicitation at any time prior to approval of the award by District Board of Trustees of Gulf Coast State College, when such approval is required. The decision to cancel a solicitation cannot be the basis for a protest pursuant to the College policy or Florida law.

- a. Reject any or all proposals received.
- b. Withdraw this RFP.
- c. Select and award any portion of any or all proposal items.
- d. Waive minor informalities and irregularities in the proposer's submittal.

A proposal may be rejected if it is non-responsive or does not conform to the requirements and instructions in this RFP. A proposal may be non-responsive by reasons including, but not limited to, failure to utilize or complete prescribed forms, conditional proposals, incomplete proposals, indefinite or ambiguous proposals, failure to meet deadlines and improper and/or undated signatures. Other conditions which may cause rejection of proposals include evidence of collusion among proposers, obvious lack of experience or expertise to perform the required work, submission of more than one proposal for the same work from an individual, firm or corporation under the same or a different name, failure to perform or meet financial obligations on previous contracts. Proposals will be rejected if not delivered on or before the date and time specified as the due date for submission.

9. Execution of Agreement

GCSC will agree to a contract with successful Firm. The Firm selected by the GCSC shall submit a schedule of values to be used to determine a payment draw schedule to the GCSC at or before the time of Notice of Award. The draw schedule shall be subject to review, modification and approval by the GCSC. The total of the Schedule of Values in the draw schedule will be the fixed fee contract amount. No invoices will be processed until GCSC staff has approved the schedule of values and received a signed contract by both parties.

The terms and conditions of this contract are fixed price and fixed time. The Architect/Engineering/Contractor Firm's negotiated fee is to be a fixed price for completing the scope of work detailed in this RFP.

The successful proposer shall, within 10 days after receipt of the Notice of Award and the contract forms or documents, sign and deliver to the GCSC Procurement Director all required contract documents. The awarded proposer shall also deliver the policies of insurance or insurance certificate as required. All insurance documents shall be approved by the GCSC Administration & Finance Office before the successful proposer may proceed with the work.

Gulf Coast State College reserves the right to terminate agreement at no additional cost due to the lack of and/or poor services, including proposer not meeting terms set forth in this RFP after Awarded.

Proposed compensation will only be considered during the negotiation phase of the procurement. Proposers are prohibited from including any compensation, fee or cost information in proposal.

10. Representations

Information obtained from an officer, agent, or employee of GCSC or any other person shall not affect the risks or obligations assumed by the Proposer or relieve the Proposer from fulfilling any of the conditions of the contract.

11. Point of Contact

The GCSC Procurement Director will be the only point of contact for this Request for Proposal. **Under no circumstances may a proposer contact any member of the District Board of Trustees, GCSC administrators, or GCSC employees concerning this solicitation until after award.** Any such contact may result in proposal disqualification.

12. Proposal Protest

All protests shall be filed in accordance with Section 120.57(3), Florida Statutes, and the GCSC procurement policies. Failure to file a protest within the time prescribed in Section 120.57(3), Florida Statutes, shall constitute a waiver of proceedings under Chapter 120, Florida Statutes. Protestors are required to post a bond equal to 5% of the accepted proposal per Florida Statute 255.0516. GCSC will follow the statutory procedures for the resolution of protests arising from the contracting process. It is the sole responsibility of the protestor to know and follow all procedures according to Florida Statutes.

13. Prohibition on Contingency Fees

Any Firm awarded a contract pursuant to this RFP must warrant that it has not employed or retained any company or person, other than a bona fide employee working solely for that firm, to solicit or secure the contract and that the firm has not paid or agreed to pay any person, company, corporation, individual or firm, other than a bona fide employee working solely for the firm, any fee, commission, percentage, gift or other consideration contingent upon or resulting from the award or making of the contract.

14. Public Records

Upon award recommendation or thirty (30) calendar days after opening, whichever occurs first, all proposals or other information submitted in response to this RFP shall be public record subject to public disclosure pursuant to the Public Records Act, Chapter 119, Florida Statutes. If a Proposer believes any information submitted to GCSC is exempt from disclosure under the Public Records Act, it must specifically identify the exempt information and provide the statutory basis for the exemption. The

Proposer also must provide one additional copy of the submittal on which any information the Proposer claims is exempt has been redacted. The Proposer will be responsible for all costs of GCSC, including attorney's fees, associated with defending any asserted exemption from disclosure under the Public Records Act.

Submittal/Evaluation Information

1. Representatives from the Procurement Department will review the Request For Proposals (RFP) for completeness and meeting the requirements as per RFP. Those RFPs deemed complete and responsive will be forwarded to a GCSC Evaluation Committee.
2. The GCSC Evaluation Committee shall evaluate the RFPs based on the evaluation criteria in Section 287.055(4)(b), Florida Statutes and this RFP, and may request oral presentations by no fewer than **three (3)** Proposers, if determined necessary. The GCSC Evaluation Committee will recommend to the GCSC Board of Trustees the firm deemed to be most qualified ranked in order of preference according to scores.

Upon approval by the Board of Trustees and authorization to GCSC staff to negotiate a contract with the top ranked firm, negotiations shall proceed with the firm ranked highest. If staff is unable to negotiate an agreeable contract with the top firm, they will initiate negotiations with the next highest ranked firm and so on until a contract can be reached or GCSC decides to reject all proposals and withdraw this RFP.

3. The provisions of this RFP from Proposers shall not create any legal or other obligation between GCSC and any Proposer except as expressly set out in this RFP.
4. GCSC will make the selections primarily on the basis of the response to this RFP, addendums and any further information received from Proposers during presentations. Although information additional to that requested in this RFP may be provided by respondents, any consideration of this information shall be at the discretion of GCSC. GCSC shall be the sole judge of the award of this project to the respondent considered by the GCSC to offer the best overall response with a resulting negotiated agreement that is most advantageous and in the best interest of GCSC.
5. Firms will be evaluated based on the following criteria and scoring method.

**Gulf Coast State College
RFP# 1-2016/2017 Design of New Softball Field Evaluation Form**

Criteria for Evaluation Proposals	Points Range	Maximum Points	Firm 1	Firm 2	Firm 3	Firm X	Comments/Notes
Company's Qualifications/ Approach and Understanding	0 - 50	40					
Past performance of firm on similar projects	0 - 15	15					
Recent, current and projected workloads of the firm	0 – 10	10					
Schedule to design and constructed	0 – 15	15					
Pricing	0 – 20	20					
TOTAL:	0-100	100					

The college evaluation committee will review and read the information provided in the vendor proposal packets and rate criteria according to this Evaluation Form.

PROJECT SCOPE AND GOALS

Scope:

The purpose of the Request for Proposals (RFP) is to solicit competitive proposals from qualified Architect/Engineering/Contractor Roof design-build teams with experience in designing and constructing roofs. The Design-build team must have been the principle firm in charge of the design of a roof and have a contractor with experience with roof retrofits. Design-build team shall be responsible for engineered stamped roof plans including surveying, verifying existing conditions, permitting, coordination with other agencies, technical specifications, a 20 year roof warranty, and all other work associated with complete design and construction. Design-build team shall submit for all proper permits. During construction the design-build team contractor is responsible for only tearing off what can be replaced in that work day. The contractor shall provide a method to terminate work at the end of each work day that roof does not leak, that is the only acceptable method to college. Design-build team will be held responsible for all damages caused by improper construction of new roof.

Alternate #1: design team will propose to Gulf Coast State College a tear off of existing roof and install a new roof with new products. Provide a 20 year roof warranty. New roof products can be Single –ply, Thermoplastic Roofing, Ethylene Propylene Diene Terpolymer (EPDM) and etc. Pricing will be Lump Sum.

Alternate #2: will be a proposal to install a light weight metal truss with a standing seam metal roof to match the existing student union west roof. This roofing system will have a 20 year warranty or greater. In designing new metal roof, designer will have to be creative and not block glass block windows. Extend existing stacks, vents, and equipment. Pricing will be Lump Sum

The college reserves the right to ask vendor for additional information to help make a better decision on Request for Proposals and services.

Performance Standards:

The design shall be consistent with federal and state standards for Construction of State Building. The project shall be designed and constructed in accordance with the following standards:

- **Latest addition of the Florida Building Codes**
- **State of Florida Department of Management Services Policy Number REDM 08-104 (Energy Star)**
- **State Requirements for Educational Facilities (SREF)**
- **Latest OSHA Requirements for roofing**

Surveying:

All survey work required for the project shall be the responsibility of the Architect/Engineering Firm.

Meetings:

If GCSC moves forward with construction of project, GCSC will chair the Kickoff Meeting. Subsequent to that meeting, the Architect/Engineering Firm shall be responsible for scheduling, organizing, preparing agendas for, running (chairing) and recording all meetings necessary for design, as well as preparing and distributing meeting minutes. Meetings to be held include, but are not limited to:

- Project Kick-off meeting with GCSC staff
- Design Review meetings with GCSC staff at the Conceptual, 60%, and 90% phases of design
- Meetings with key stakeholders, and other agencies as necessary to determine user requirements
- Coordination meetings with utility companies, permitting agencies, etc.
- Pre-Bid Meeting for construction phase of project.
- Design Progress Update Meetings

Construction Plans and Specifications, Preparation, Review, and Approval:

Plans shall be submitted to the GCSC Vice President of Administration & Finance and Director of Procurement for review and coordination at the Conceptual, 60% and 90% phases of design. Three (3) copies of the plans shall be submitted for each phase, all on D size paper and an electronic pdf copy. Plans shall be submitted a minimum of 10 working days prior to the corresponding design review meeting with GCSC staff.

The final set of plans shall be signed and sealed by the Architect/Engineering Firm's Architect and Engineer in responsible charge of design, including electronic pdf version. Two (2) signed and sealed copies of the final plans shall be submitted to GCSC Procurement Department on D size paper. Additionally, a digital set of final plans shall be submitted on CD, DVD or thumb drive in PDF file format to the GCSC Procurement Department as part of close out documents. The specifications shall be submitted for review with the 90% plans. An electronic PDF copy of plans and specifications releasable for bidding shall be provided to the GCSC.

Design Documentation, Computations and Quantities:

The Architect/Engineering Firm shall submit with the final plans the design notes and computations to document the design conclusions reached during the development of the construction plans. The design notes and computation sheets shall be fully titled, numbered, dated, indexed, and signed by the designer. Computer output forms and other oversized sheets shall be folded to a standard size 8½" x 11".

The design notes and calculations shall include, but are not limited to:

- Design standards used for the project

- Documentation of decisions reached resulting from meetings, telephone conversations or site visits

Progress Reporting:

The Architect/Engineering Firm shall provide a written monthly progress report and updated project schedule each month on or before the last work day of the month to the GCSC Vice President of Administration & Finance, describing the work performed during the month and any items of concern. In addition to the monthly report the Architect/Engineering Firm shall host progress meeting at a location to be determined by GCSC staff at the request of college.

Design Information provided by the GCSC:

GCSC will provide the following information to the Architect/Engineering Firm

- Aerial photo of Student Union East roof
- Selected sheets of existing building plans

A full set of plans will be provided on CD to the proposer that's awarded the contract.

Permitting:

If GCSC moves forward with construction of the project, the Architect/Engineering/construction firm shall be responsible for identifying all required permits, preparing complete permit application packages and obtaining the permits. Contractor is responsible for picking up and paying for permits under the review of the Architect/Engineering Firm. GCSC will reimburse all permit fees. The Architect/Engineering Firm shall act as the GCSC authorized representative for permitting purposes only. If any agency rejects or denies the permit application, the Architect/Engineering Firm shall be responsible for making the changes necessary to ensure the permit is approved. Any fines levied by permitting agencies shall be the responsibility of the Architect/Engineering Firm.

Permits to be obtained may include, but are not limited to:

- Demolition permit
- Building permit

Any requests by the Firm for extension of contract time due to permitting delays must be submitted in writing to GCSC. GCSC Staff has the authority to make a determination to grant a non-compensable time extension for any impacts beyond the reasonable control of the firm in securing permits. Furthermore, as to any such impact, no modification provision will be considered by GCSC unless the firm clearly establishes that it has continuously from the beginning of the project aggressively, efficiently and effectively pursued the securing of the permits including the utilization of any and all reasonably available means and methods to overcome all impacts.

Construction Engineering and Inspection Services:

If GCSC moves forward with construction of the project, the contractor shall provide daily inspections to document work activities and progress. During construction the Architect/Engineering Firm shall review the installation of materials at least once a

week. The review is to assure that the contractors are installing specified materials in the manner of which it is intended. Report any and all deficiencies to the GCSC Vice President of Administration & Finance and/or Director of Procurement. Roofing Manufacturer of chosen product needs to visit site and inspection of product before issuing certification for 20 year warranty

Material Submittals & Shop Drawings:

During construction, the Architect/Engineering firm shall be responsible for the approval of all material submittals and Shop Drawings. Shop Drawings shall be submitted to the Architect/Engineering Firm and shall bear the stamp and signature of the Specialty Engineer. The Architect/Engineering Firm will review the Shop Drawing(s) to evaluate compliance with project drawings and specifications and provide any findings to the GCSC. GCSC will review the records of the Architect/Engineering Firm to assure that the Architect/Engineering Firm has both accepted and signed the submittals. It will be the Architect/Engineering Firm's responsibility to notify the GCSC of any specification or drawing changes that create a need for drawing or specification changes. GCSC review is not meant to be a complete and detailed review. Component submittals must be accompanied by sufficient information for adjoining components or areas of work to allow for proper evaluation of the component submitted for review. Submittal schedule shall be a part of specifications by Architect/Engineering Firm

Sequence of Construction:

The Architect/Engineering firm shall design the work in a logical manner and with the following objectives as guides:

1. Maintain or improve, to the maximum extent possible, the quality of existing operations, throughout the duration of the project.
2. Maintain reasonable direct access to adjacent properties at all time.
3. Provide an OSHA Safety and clean construction site at all times.

Project Goals:

1. Good team work between GCSC staff, the users, and Architect/Engineering/Contractor firm's team.
2. Receive high quality services and achieve aesthetically pleasing project at completion.
3. Develop good communication between all parties.
4. Coordination of design and construction phases.
5. Safety of workers, students, staff and faculty.
6. Design team design and constructed a roof to last 20 plus years.

GULF COAST STATE COLLEGE RISK MANAGEMENT REQUIREMENTS FOR PROFESSIONAL SERVICES

GCSC DEFINED

The term GCSC (wherever it may appear) is defined to mean the Gulf Coast State College itself, its Board of Trustees, officers, employees, volunteers, representatives and agents.

OTHER PARTY DEFINED

The term Other Party (wherever it may appear) is defined to mean the other person or entity which is a party to this agreement, contract or lease, any subsidiaries or affiliates, officers, employees, volunteers, representatives, agents, contractors and subcontractors.

HOLD HARMLESS

The Other Party shall indemnify and hold harmless the GCSC, their officers and employees, from liabilities, damages, losses and costs, including, but not limited to, reasonable attorney's fees, to the extent caused by the negligence, recklessness, or intentional wrongful misconduct of the Other Party and persons employed or utilized by the Other Party in the performance of the agreement or contract.

The Other Party shall hold harmless and indemnify the GCSC against all claims for financial loss with respect to the provision of or failure to provide professional or other services resulting in professional, malpractice, or errors or omissions liability arising out of performance of the agreement or contract, unless such claims are a result of the GCSC's sole negligence.

PAYMENT ON BEHALF OF GCSC

The Other Party agrees to pay on behalf of the GCSC, and to pay the cost of the GCSC's legal defense, as may be selected by the GCSC, for all claims described in the Hold Harmless paragraph.

Such payment on behalf of the GCSC shall be in addition to any and all other legal remedies available to the GCSC and shall not be considered to be the GCSC's exclusive remedy.

LOSS CONTROL/SAFETY

Precaution shall be exercised at all times by the Other Party for the protection of all persons, including employees, and property. The Other Party shall be expected to comply with all laws, regulations or ordinances related to safety and health, shall make special effort to detect hazardous conditions and shall take prompt action where loss control/safety measures should reasonably be expected.

GCSC may order work to be stopped if conditions present immediate danger to persons or property. The Other Party acknowledges that such stoppage will not shift responsibility for any damages from the Other Party to the GCSC.

DRUG FREE WORK PLACE REQUIREMENTS

All contracts or purchase orders with individuals, or organizations that wish to do business with District Board of Trustees of GCSC shall require contractors, subcontractors, vendors or consultants to have a substance abuse policy that adheres to section 440.102 Florida Statutes. In the event an employee of a supplier of goods or services is found to have violated the Substance Abuse Policy, that employee shall be denied access to the GCSC premises and job sites. In addition, if the violation is considered flagrant by the GCSC, and the GCSC is not satisfied with the actions of the contractor, subcontractor, vendor or consultant's employees, the GCSC can exercise its right to bar all of the contractor's, subcontractor's, vendor's, or consultant's employees from its premises, or decline to do business with the contractor, subcontractor, vendor or consultant in the future.

All expenses and penalties incurred by a contractor, subcontractor, vendor or consultant as a result of a violation of the GCSC's Substance Abuse Policy requirement shall be borne by the contractor, subcontractor, vendor, or consultant.

INSURANCE - BASIC COVERAGES REQUIRED

The Other Party shall procure and maintain the following described insurance, except for coverages specifically waived by the GCSC, on policies and with insurers acceptable to the GCSC.

These insurance requirements shall not limit the liability of the Other Party. The GCSC does not represent these types or amounts of insurance to be sufficient or adequate to protect the Other Party's interests or liabilities, but are merely minimums.

Except for workers compensation and professional liability, the Other Party's insurance policies shall be endorsed to name the District Board of Trustees of Gulf Coast State College as an additional insured to the extent of the GCSC's interests arising from this agreement, contract or lease. (General Liability and Business Auto)

Except for workers compensation, the Other Party waives its right of recovery against the GCSC, to the extent permitted by its insurance policies.

The Other Party's deductibles/self-insured retentions shall be disclosed to the GCSC and may be disapproved by the GCSC. They shall be reduced or eliminated at the option of the GCSC. The Other Party is responsible for the amount of any deductible or self-insured retention.

Insurance required of the Other Party or any other insurance of the Other Party shall be considered primary, and insurance of the GCSC shall be considered excess, as may be

applicable to claims which arise out of the Hold Harmless, Payment on Behalf of GCSC, Insurance, Certificates of Insurance and any Additional Insurance provisions of this agreement, contract or lease.

Workers Compensation Coverage

The Other Party shall purchase and maintain workers compensation insurance for all workers compensation obligations imposed by state law and employer's liability limits of at least \$100,000 each accident and \$100,000 each employee/\$500,000 policy limit for disease.

The Other Party shall also purchase any other coverages required by law for the benefit of employees.

General, Automobile and Excess or Umbrella Liability Coverage

The Other Party shall purchase and maintain coverage on forms no more restrictive than the latest editions of the Commercial General Liability and Business Auto policies of the Insurance Services Office.

Minimum limits of \$1,000,000 per occurrence for all liability must be provided, with excess or umbrella insurance making up the difference, if any, between the policy limits of underlying policies (including employers liability required in the Workers Compensation Coverage section) and the total amount of coverage required.

Commercial General Liability Coverage - Occurrence Form Required

Coverage A shall include bodily injury and property damage liability for premises, operations, products and completed operations, independent contractors, contractual liability covering this agreement, contract or lease, broad form property damage, and property damage resulting from explosion, collapse or underground (x,c,u) exposures.

Coverage B shall include personal injury.

Coverage C, medical payments, is not required.

The Other Party is required to continue to purchase products and completed operations coverage, at least to satisfy this agreement, contract or lease, for a minimum of three years beyond the GCSC's acceptance of renovation or construction projects.

Business Auto Liability Coverage

Business Auto Liability coverage is to include bodily injury and property damage arising out of ownership, maintenance or use of any auto, including owned, nonowned and hired automobiles and employee nonownership use.

Excess or Umbrella Liability Coverage

Umbrella Liability insurance is preferred, but an Excess Liability equivalent may be allowed. Whichever type of coverage is provided, it should be at least "following form" and shall not be more restrictive than the underlying insurance policy coverages.

ADDITIONAL INSURANCE

Professional Liability/Malpractice/Errors or Omissions Insurance

The Other Party shall purchase and maintain professional liability or malpractice or errors or omissions insurance with minimum limits of \$1,000,000 per occurrence.

If a claims made form of coverage is provided, the retroactive date of coverage shall be no later than the inception date of claims made coverage, unless the prior policy was extended indefinitely to cover prior acts.

Coverage shall be extended beyond the policy year either by a supplemental extended reporting period (ERP) of as great duration as available, and with no less coverage and with reinstated aggregate limits, or by requiring that any new policy provide a retroactive date no later than the inception date of claims made coverage.

EVIDENCE/CERTIFICATES OF INSURANCE

Certificate Holder will be addressed as the Gulf Coast State College, 5230 West U.S Highway, Panama City, Florida 32401. All certificates, cancellation, nonrenewal or adverse change notices should be mailed to this address. As outlined above, the Gulf Coast State College is to be named as Additional Insured on General Liability and Business Auto.

Each Certificate will address the service being rendered to the GCSC by the Other Party.

Required insurance shall be documented in Certificates of Insurance which provide that the GCSC shall be notified at least 30 days in advance of cancellation, nonrenewal or adverse change.

New Certificates of Insurance are to be provided to the GCSC at least 15 days prior to coverage renewals.

If requested by the GCSC, the Other Party shall furnish complete copies of the Other Party's insurance policies, forms and endorsements.

For Commercial General Liability coverage the Other Party shall, at the option of the GCSC, provide an indication of the amount of claims payments or reserves chargeable to the aggregate amount of liability coverage.

Receipt of certificates or other documentation of insurance or policies or copies of policies by the GCSC, or by any of its representatives, which indicate less coverage than required does not constitute a waiver of the Other Party's obligation to fulfill the insurance requirements herein.

ADDENDUM ACKNOWLEDGEMENT

I acknowledge receipt of the following addenda:

ADDENDUM NO. _____

DATED _____

ADDENDUM NO. _____

DATED _____

ADDENDUM NO. _____

DATED _____

ADDENDUM NO. _____

DATED _____

ADDENDUM NO. _____

DATED _____

Name of Firm: _____

Authorized Signature: _____

Printed Name: _____

Title: _____

Date: _____

It is the responsibility of the firm to ensure that they have received addendums if issued. Call (850) 872-3843 or email fbrown3@gulfcoast.edu prior to submitting your proposal to ensure that you have received addendums.

ANTI-COLLUSION CLAUSE

Firm certifies that their response is made without prior understanding, agreement or connection with any Corporation, Firm or person submitting a response for the same services and is in all respects fair and without collusion or fraud.

Name of Firm: _____

Authorized Signature: _____

Printed Name: _____

Title: _____

Date: _____

CONFLICT OF INTEREST DISCLOSURE FORM

For purposes of determining any possible conflict of interest, all firms, must disclose if any District Board of Trustees of Gulf Coast State College(s), employee(s), elected officials(s), of if any of its agencies is also an owner, corporate officer, agency, employee, etc., of their firm.

Indicate either "yes" (a GCSC employee, elected official, or agency is also associated with your firm), or "no". If yes, give person(s) name(s) and position(s) with your firm.

YES _____

NO _____

NAME(S)

POSITION(S)

Name of Firm: _____

Authorized Signature: _____

Printed Name: _____

Title: _____

Date: _____

DRUG FREE WORKPLACE
Section 287.087 Florida Statutes

Preference shall be given to businesses with drug-free workplace programs. Whenever two or more proposals, which are equal with respect to price, quality, and service, are received by the GCSC for the procurement of commodities or contractual services, a proposal received from a business that certifies that it has implemented a drug-free workplace program shall be given preference in the award process. Established procedures for processing tie bids will be followed if none of the tied vendors have a drug-free workplace program. To have a drug-free workplace program, a business shall:

1. Publish a statement notifying employees that the unlawful manufacture, distribution, dispensing, possession, or use of a controlled substance is prohibited in the workplace and specifying the actions that will be taken against employees for violations of such prohibition.
2. Inform employees about the dangers of drug abuse in the workplace, the business's policy of maintaining a drug-free workplace, any available drug counseling, rehabilitation, and employee assistance programs, and the penalties that may be imposed upon employees for drug abuse violations.
3. Give each employee engaged in providing the commodities or contractual services that are under Bid a copy of the statement specified in subsection (1).
4. In the statement specified in subsection (1), notify the employees that, as a condition of working on the commodities or contractual services that are under Bid, the employees will abide by the terms of the statement and will notify the employer of any conviction of, or plea of guilty or nolo contendere to, any violation of Chapter 893 or of any controlled substance law of the United States or any state, for a violation occurring in the workplace no later than five (5) days after such conviction.
5. Impose a sanction on, or require the satisfactory participation in a drug abuse assistance or rehabilitation program if such is available in the employee's community, by an employee who is so convicted.
6. Make a good faith effort to continue to maintain a drug-free workplace through implementation of this section.

As the person authorized to sign the statement, I certify that this firm complies fully with the above requirements.

Name of Firm: _____

Authorized Signature: _____

Printed Name: _____

Title: _____

Date: _____

E-VERIFY

Vendor/Consultant acknowledges and agrees to the following: Vendor/Consultant shall utilize the U.S. Department of Homeland Security's E-Verify system, in accordance with the terms governing use of the system, to confirm the employment eligibility of:

1. All persons employed by the Vendor/Consultant during the term of the Contract to perform employment duties within Florida; and

2. All persons, including subcontractors, assigned by the Vendor/Consultant to perform work pursuant to the contract with GCSC.

Name of Firm: _____

Authorized Signature: _____

Printed Name: _____

Title: _____

Date: _____

SWORN STATEMENT PURSUANT TO SECTION 287.133(3)(a),
FLORIDA STATUTES,
PUBLIC ENTITY CRIMES

THIS FORM MUST BE SIGNED AND SWORN TO IN THE PRESENCE OF A NOTARY PUBLIC OR OTHER OFFICIAL AUTHORIZED TO ADMINISTER OATHS.

1. This sworn statement is submitted to _____

by _____

for _____

whose business address is

and (if applicable) its Federal Employer Identification Number (FEIN) is _____

(If the entity has no FEIN, include the Social Security Number of the individual signing this sworn statement:

2. I understand that a “public entity crime” as defined in Paragraph 287.133 (1)(g), Florida Statutes, means a violation of any state or federal law by a person with respect to and directly related to the transaction of business with any public entity or with an agency or political subdivision of any other state or of the United States, including, but not limited to, any bid or contract for goods or services to be provided to any public entity or an agency or political subdivision of any other state or of the United States and involving antitrust, fraud, theft, bribery, collusion, racketeering, conspiracy, or material misrepresentation.
3. I understand that “convicted” or “conviction” as defined in Paragraph 287.133 (1)(b), Florida Statutes, means a finding of guilt or a conviction of a public entity crime, with or without an adjudication of guilt, in any federal or state trial court of record relating to charges brought by indictment or information after July 1, 1989, as a result of a jury verdict, non jury trial, or entry of a plea of guilty or nolo contendere.
4. I understand that an “affiliate” as defined in Paragraph 287.133(1)(a), Florida Statutes, means:
 - a. A predecessor or successor of a person convicted of a public entity crime; or
 - b. An entity under the control of any natural person who is active in the management of the entity and who has been convicted of a public entity crime. The term “affiliate” includes officers, directors, executives, partners, shareholders, employees, members, and agents who are active in the management of an affiliate. The ownership by one person of shares constituting a controlling interest in another person, or a pooling of equipment or income among persons when not for fair market value under an arm's length agreement, shall be a prima facie case that one person controls another person. A person who knowingly enters into a joint venture with a person who has been convicted of a public entity crime in Florida during the preceding 36 months shall be considered an affiliate.

5. I understand that a "person" as defined in Paragraph 287.133(1)I, Florida Statutes, means any natural person or entity organized under the laws of any state or of the United States with the legal power to enter in to a binding contract and which bids or applied to bid on contracts for the provision of goods or services let by a public entity, or which otherwise transacts or applies to transact business with a public entity. The term "person" includes those officers, directors, executives, partners, shareholders, employees, members, and agents who are active in management of an entity.
6. Based on information and belief, the statement which I have marked below is true in relation to the entity submitting this sworn statement. [indicate which statement applies.]

_____Neither the entity submitting this sworn statement, nor any of its officers, directors, executives, partners, shareholders, employees, members, or agents who are active in the management of the entity, nor any affiliate of the entity has been charged with and convicted of a public entity crime subsequent to July 1, 1989.

_____The entity submitting this sworn statement, or one or more of its officers, directors, executives, partners, share holders, employees, members, or agents who are active in the management of the entity, or an affiliate of the entity has been charged with and convicted of a public entity crime subsequent to July 1, 1989.

_____The entity submitting this sworn statement, or one or more of its officers, directors, executives, partners, shareholders, employees, members, or agents who are active in the management of the entity, or an affiliate of the entity has been charged with and convicted of a public entity crime subsequent to July 1, 1989. However, there has been a subsequent proceeding before a Hearing Office of the State of Florida, Division of Administrative Hearings and the Final Order entered by the Hearing Officer determined that it was not in the public interest to place the entity submitting this sworn statement on the convicted vender list. [attach a copy of the final order]

I UNDERSTAND THAT THE SUBMISSION OF THIS FORM TO THE CONTRACTING OFFICER FOR THE PUBLIC ENTITY IDENTIFIED IN PARAGRAPH 1 (ONE) ABOVE IS FOR THE PUBLIC ENTITY ONLY AND, THAT THIS FORM IS VALID THROUGH DECEMBER 31 OF THE CALENDAR YEAR IN WHICH IT IS FILED. I ALSO UNDERSTAND THAT I AM REQUIRED TO INFORM THE PUBLIC ENTITY PRIOR TO ENTERING INTO A CONTRACT IN EXCESS OF THE THRESHOLD AMOUNT PROVIDED IN SECTION 287.017, FLORIDA STATUTES FOR CATEGORY TWO OF ANY CHANGE IN THE INFORMATION CONTAINED IN THIS FORM.

Signature

Sworn to and subscribed before me on this _____ day of _____, 20____.

Personally known _____ OR Produced identification _____

Notary Public- State of _____

My commission expires: _____
[printed, typed or stamped commissioned name of notary public]

SUB-CONTRACTORS FORM

As the Proposer, I submit a listing of the Sub-Contractors which I shall use to accomplish the Work. Sub-Contractors are listed by name, address, amount of work and item of work. If none, please state so.

Subcontractor Name, Address, & License #: _____

Work to be performed and amount: _____

Subcontractor Name, Address, & License #: _____

Work to be performed and amount: _____

Subcontractor Name, Address, & License #: _____

Work to be performed and amount: _____

Subcontractor Name, Address, & License #: _____

Work to be performed and amount: _____

Subcontractor Name, Address, & License #: _____

Work to be performed and amount: _____

Subcontractor Name, Address, & License #: _____

Work to be performed and amount: _____

Name of Firm: _____

Authorized Signature: _____

Printed Name: _____

Title: _____

Date: _____

LABOR AND MATERIAL PAYMENT BOND

BY THIS BOND, We, _____ as Principal and _____, a corporation, as Surety, are bound to the DISTRICT BOARD OF TRUSTEES OF GULF COAST STATE COLLEGE, as College, in the sum of \$_____ for the payment of which we bind ourselves, our heirs, personal representatives, successors, and assigns, jointly and severally. Principal and GCSC entered into a contract dated _____, 2016 for _____, which is incorporated by reference.

THE CONDITIONS of this bond is such that

1. If the Principal shall promptly make payment to all persons, firms, subcontractors, and corporations furnishing materials for or performing labor in the prosecution of the work provided for in such Contract, and any authorized extension or modification thereof, including all insurance premiums on said work, and for all labor, performed in such work whether by subcontractor or otherwise, then this obligation shall be void. Otherwise, it shall remain in full force and effect.

2. If Surety, for value received, hereby stipulates and agrees that no change, extension of time, alteration or addition to the terms of the Contract or to the work to be performed thereunder or the specifications accompanying the same shall in any wise affect its obligation on this bond, and it does hereby waive notice of any such change, extension of time, alteration or addition to the terms of the Contract or to the work or to the specifications.

Further, no final settlement between GCSC College and the Contractor shall abridge the right of any beneficiary hereunder, whose claim may be unsatisfied.

Now, therefore, if the Contractor shall promptly make payment to all claimants, defined below, for all labor and material used or required for use in performing the obligations of this Contract, then this obligation shall be null and void; otherwise it shall remain in full force and effect.

Signed and Sealed this _____ day of _____, 2016.

CORPORATE PRINCIPAL

Attest:

By: _____

Seal:

Its: _____

Acknowledged and subscribed on _____, 2016, before the undersigned authority by _____, as the _____ of the Corporation named as Principal and with due authorization of the Corporation.

Notary Public

SURETY

Attest:

By: _____

Seal:

Countersigned:

By: _____

Attorney-in-Fact, State of Florida

PERFORMANCE BOND

BY THIS BOND, We, _____ as Principal and _____, a corporation, as Surety, are bound to the DISTRICT BOARD OF TRUSTEES OF GULF COAST STATE COLLEGE, as College, in the sum of \$_____ for the payment of which we bind ourselves, our heirs, personal representatives, successors, and assigns, jointly and severally. THE CONDITIONS of this bond are that if Principal:

1. Performs the contract dated _____, 2016, between Principal and the GCSC College for construction of _____, the contract being made a part of this bond by reference, at the times and in the manner prescribed in the contract; and
2. Promptly makes payments to all claimants, as defined in section 255.05(1), Florida Statutes, supplying Principal with labor materials or supplies, used directly or indirectly by Principal in the prosecution of the work provided for in the contract; and
3. Pays County all losses, damages, expenses, costs, and attorney's fees, including appellate proceedings, that GCSC sustains because of a default by Principal under the contract; and
4. Performs the guarantee and warranty of all work and materials furnished under the contract for the time specified in the contract, then this bond is void; otherwise it remains in full force.
5. Any action instituted by a claimant under this bond for payment must be in accordance with the notice and time limitation provisions in Section [255.05](#)(2), Florida Statutes. Any changes in or under the contract documents and compliance or noncompliance with any formalities connected with the contract or the changes does not affect Surety's obligation under this bond.

The Surety and the Contractor consent and yield to the jurisdiction of the Civil Courts in and for Bay County, Florida.

CORPORATE PRINCIPAL

Attest:

By: _____

Seal:

Its: _____

Acknowledged and subscribed on _____, 2016, before the undersigned authority by _____, as the _____ of the Corporation named as Principal and with due authorization of the Corporation.

Notary Public

SURETY

Attest:

By: _____

Seal:

Countersigned:

By: _____

PROPOSAL FORM

This proposal of _____, hereinafter called "Proposer," organized and existing under the laws of the State of _____ doing business as _____ (Insert a corporation", "a partnership" or "an individual" as applicable), is hereby submitted to the District Board of Trustees of Gulf Coast State College, hereinafter called "OWNER."

In compliance with the Advertisement for Proposals, Proposer hereby proposes to perform all work for GCSC Student Union East Roof Design-build Project as detailed in this solicitation.

By submission of this Proposal, each Proposer certifies, and in the case of a joint Proposal each party thereto certifies as to its own organization, that this Proposal has been arrived at independently, without consultation, communication or agreement as to any matter relating to this solicitation with any other competitor.

Alternate #1:
Type of Roof _____ Cost \$ _____ L.S

Alternate#2:
Metal Roof _____ Cost \$ _____ L.S

Signature: _____

Date _____

Print Name _____

Title _____

RFP #2-2016/2017 SCHEDULE:

10/28/16 - 12/01/16	Advertise RFP
11/07/16	Pre-Proposal Meeting & Roof Walk-through (9:00AM, CST) We will meet at the Front Entrance of Student Union East
11/16/16	Last Day of questions in by 4:00pm
11/18/16	Owner response to Proposers questions and Post on College Procurement website (gulfcoast.edu/procurement)
12/01/16	Proposals are due 2:00pm and shall be opened by GCSC at 2:00pm
12/07/16	Selection Committee review and generate shortlist
12/09/16	Post Intend to Award
12/15/16	DBOT award to successful proposer
12/16/16	Notice of Award and post on website

EXHIBIT A

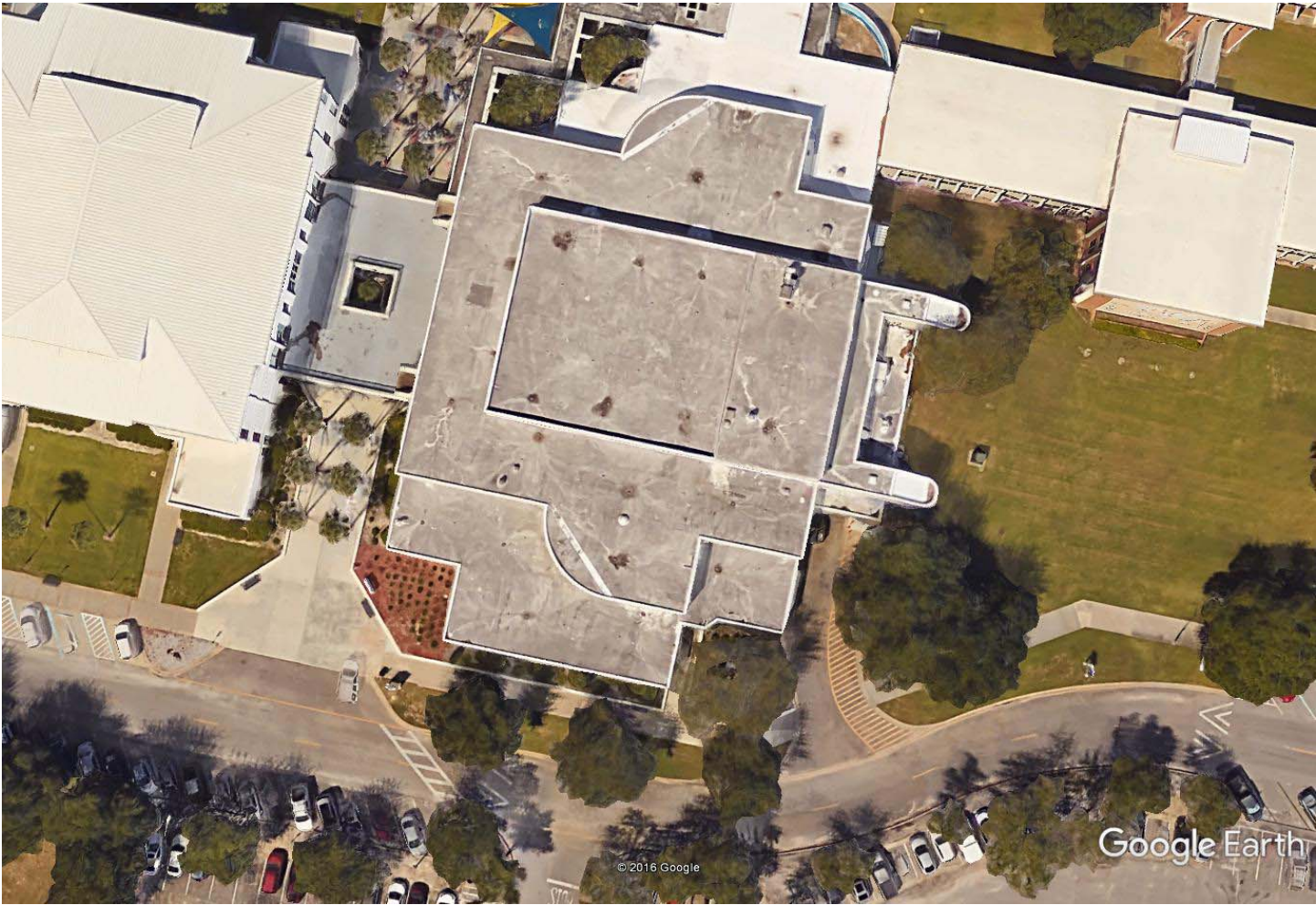

© 2016 Google

Google Earth

Google Earth

feet
meters



EXHIBIT B

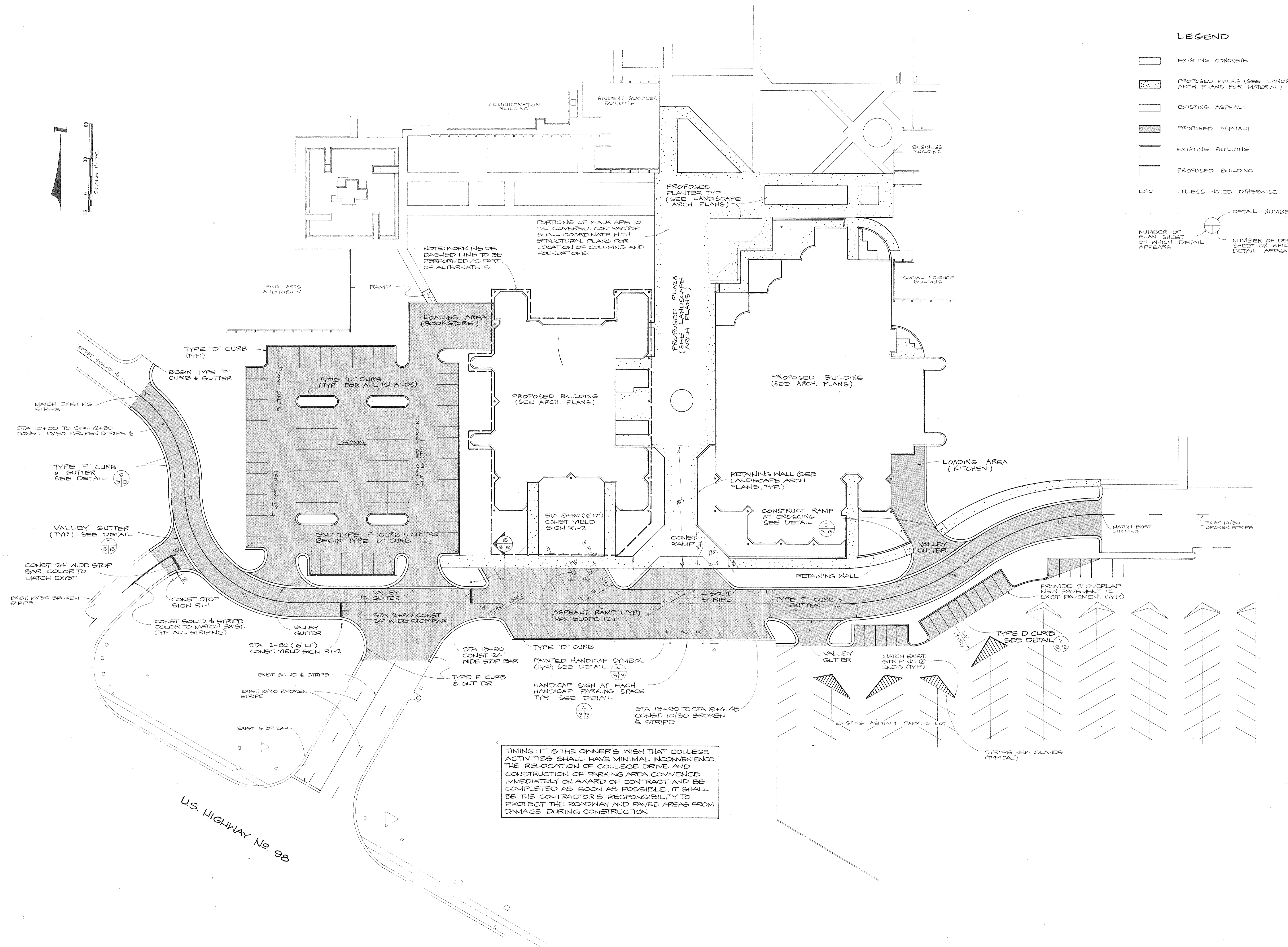
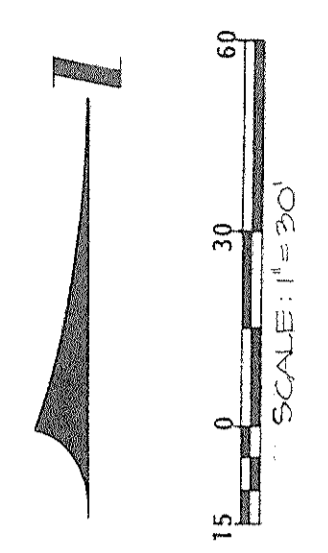

- LEGEND**
- EXISTING CONCRETE
 - PROPOSED WALKS (SEE LANDSCAPE ARCH. PLANS FOR MATERIAL)
 - EXISTING ASPHALT
 - PROPOSED ASPHALT
 - EXISTING BUILDING
 - PROPOSED BUILDING
 - UNO UNLESS NOTED OTHERWISE

DETAIL NUMBER

NUMBER OF PLAN SHEET ON WHICH DETAIL APPEARS

NUMBER OF DETAIL SHEET ON WHICH DETAIL APPEARS

TIMING: IT IS THE OWNER'S WISH THAT COLLEGE ACTIVITIES SHALL HAVE MINIMAL INCONVENIENCE. THE RELOCATION OF COLLEGE DRIVE AND CONSTRUCTION OF PARKING AREA COMMENCE IMMEDIATELY ON AWARD OF CONTRACT AND BE COMPLETED AS SOON AS POSSIBLE. IT SHALL BE THE CONTRACTOR'S RESPONSIBILITY TO PROTECT THE ROADWAY AND PAVED AREAS FROM DAMAGE DURING CONSTRUCTION.

U.S. HIGHWAY No. 98

NO.	DATE	REVISION	BY	CHK

DESIGN: M.H.	CHECKED: M.H.	DATE: 10-22-80
DRAWN: N.P.	APP'D: M.H.	
IN ASSOCIATION WITH:		
SMITH BOZARTH FULLER		
ARCHITECTS & PLANNERS, P.A.		
Panama City, FL		

STUDENT SERVICES CENTER
SITE PLAN

BUCHANAN & HARPER, INC.
ENGINEERING - PLANNING - SURVEYING - LANDSCAPE ARCHITECTURE
1312 BALBOA AVENUE - PANAMA CITY, FLORIDA 32401 - (904) 763-7427

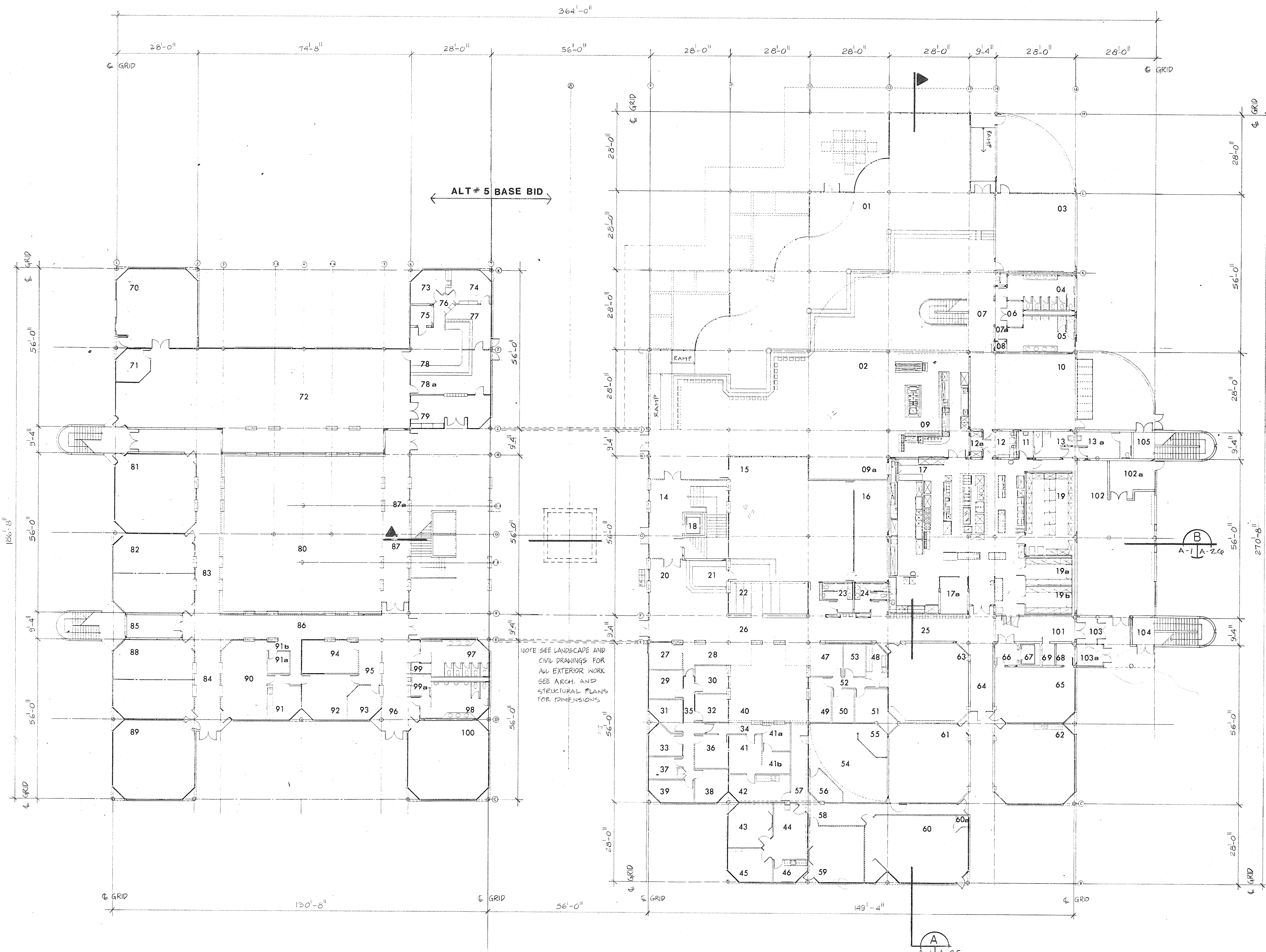

I.M.T.S. BUILDING

STUDENT SERVICES BUILDING

NO.	DATE	REVISION	BY	CHK

DESIGN: EDC
 DRAWN: JLL
 CHECKED: EDC
 APPROVED: EDC
 DATE: 12-21-25

STUDENT SERVICES CENTER, GULF COAST COMMUNITY COLLEGE

BRIEL RHAME POYNTER & HOUSER
 ARCHITECTS - ENGINEERS, INC. Tallahassee, FL
 IN ASSOCIATION WITH
 SMITH BOZARTH FULLER
 ARCHITECTS & PLANNERS, P.A. Panama City, FL

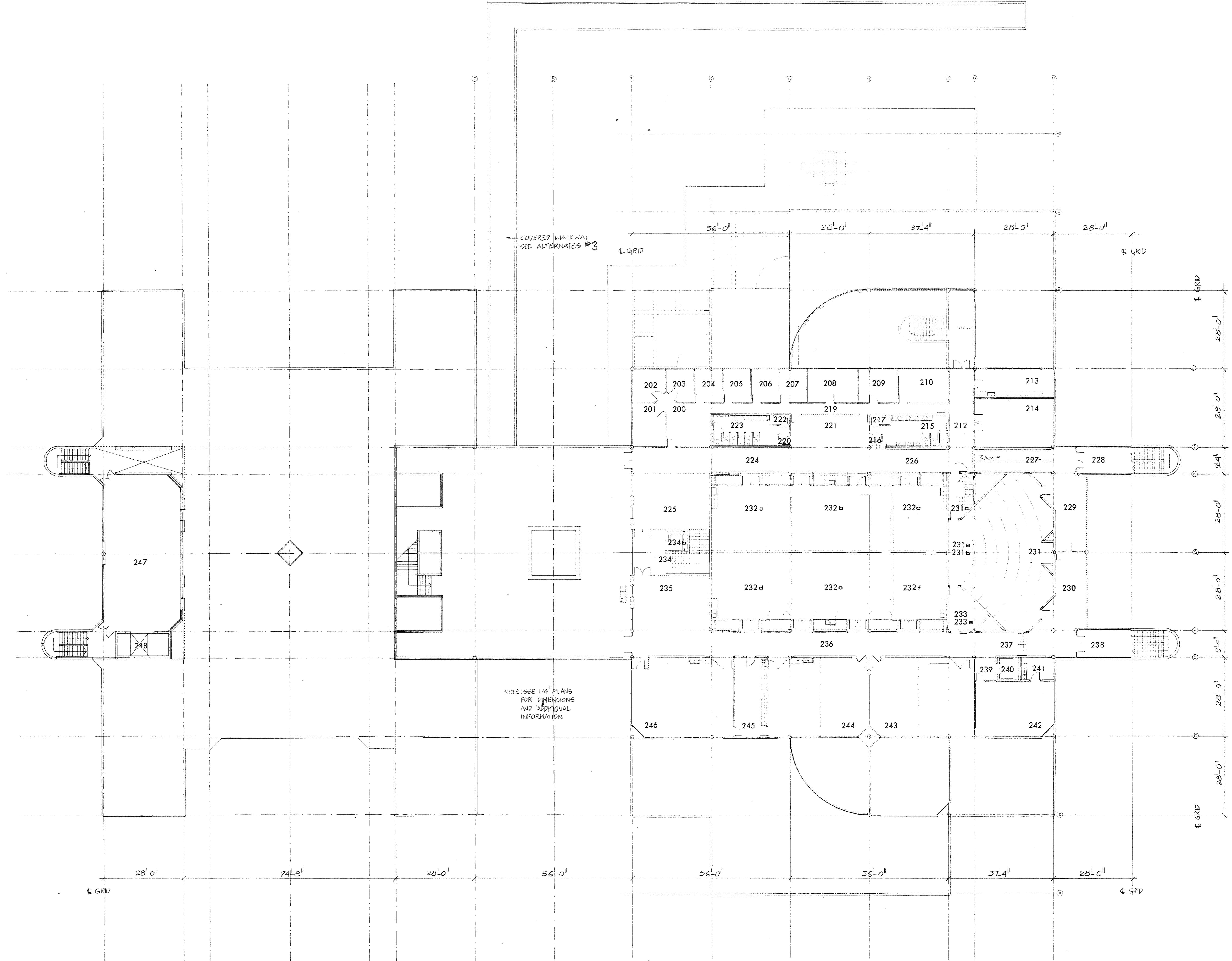

I.M.T.S. BUILDING

STUDENT SERVICES BUILDING

NO.	DATE	REVISION	BY	CHK

DESIGN: EDC
DRAWN: LU
CHECKED: EDC
APPROVED: EDC
DATE: 10-21-20

STUDENT SERVICES CENTER, GULF COAST COMMUNITY COLLEGE

BRIEL RHAME POYNTER & HOUSER
 ARCHITECTS - ENGINEERS, INC. Tallahassee, FL
 IN ASSOCIATION WITH
 SMITH BOZARTH FULLER
 ARCHITECTS & PLANNERS, P.A. Panama City, FL

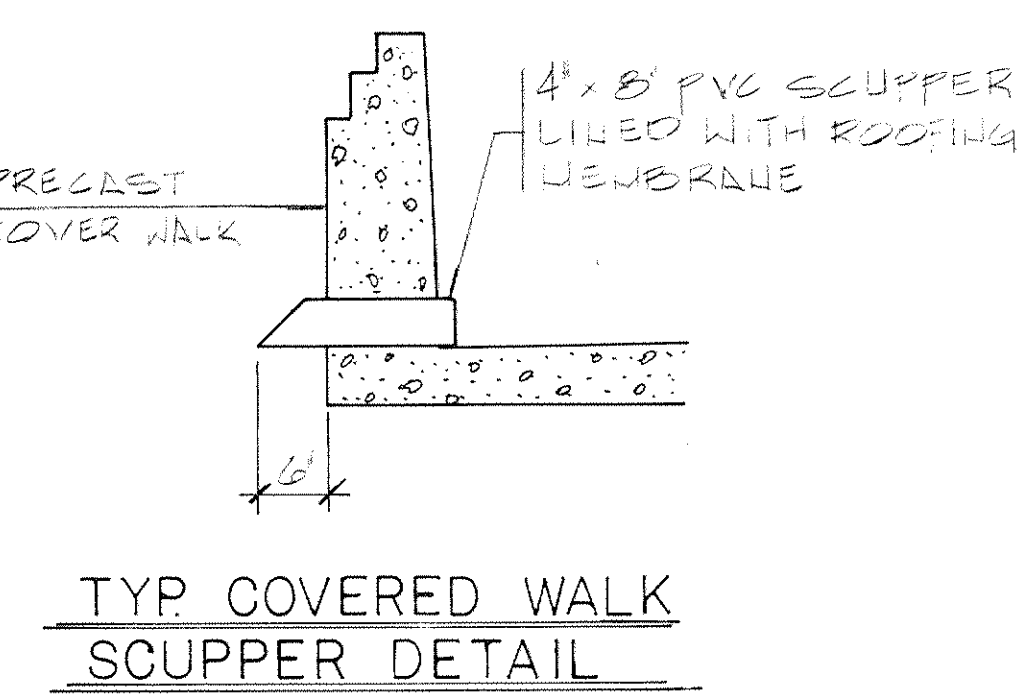
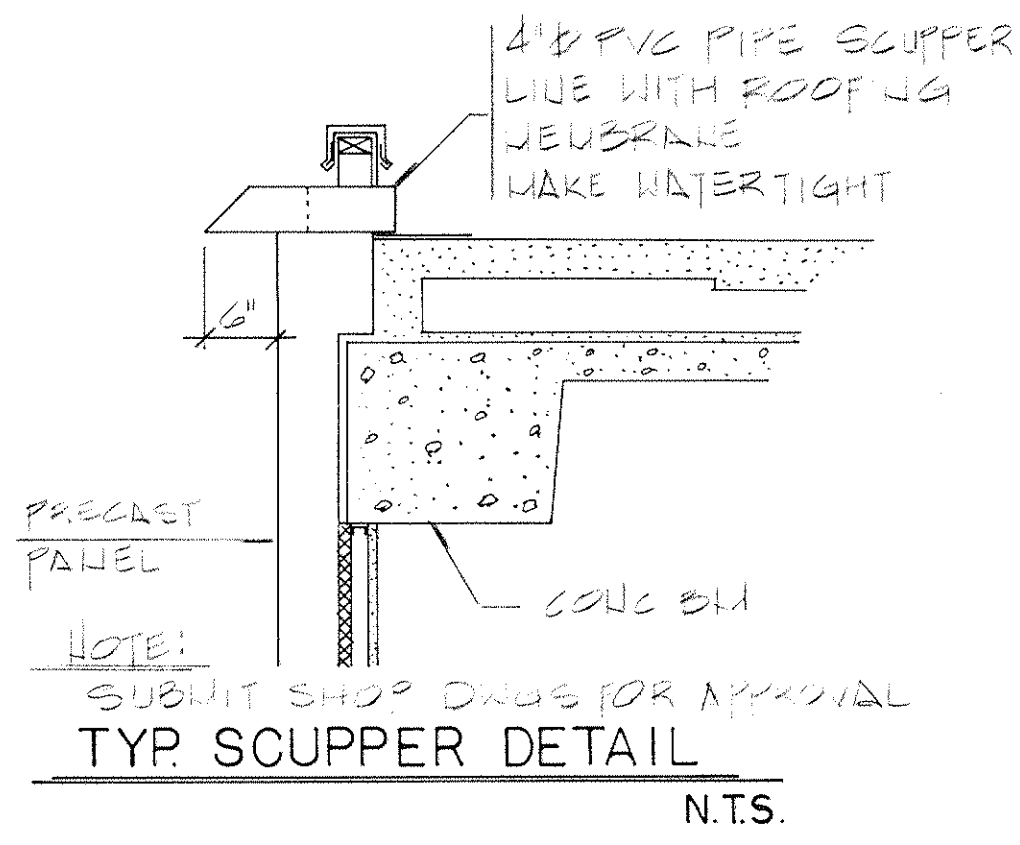
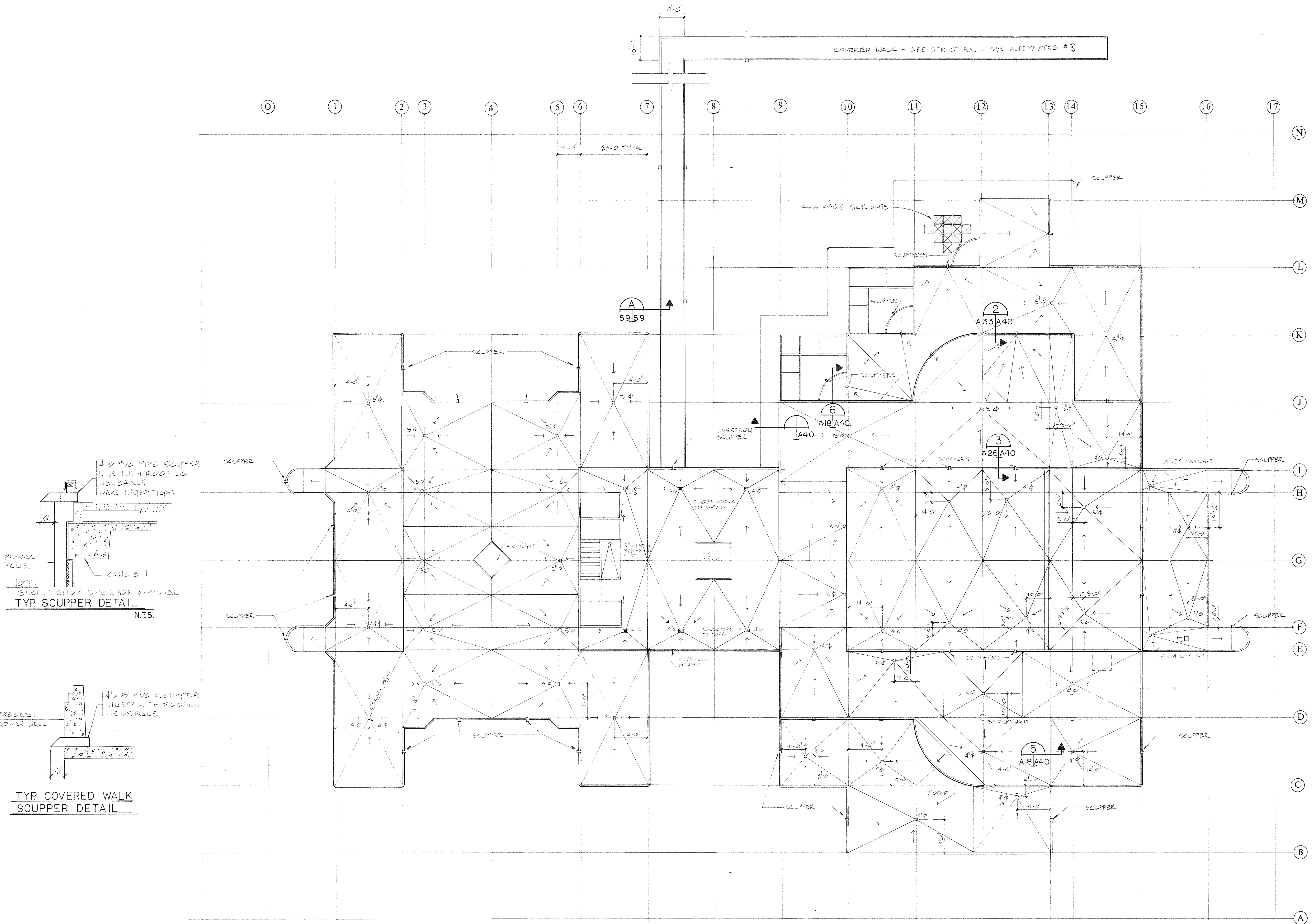

LEGEND

ROOF DRAIN	○
SLOPE 1/4" Ft MIN	↘
SCUPPER	U
DECK DRAIN	□

NO.	DATE	REVISION	BY	CHK

DESIGN BY: BREL PHAME POYNIER & HOUSER
 DRAWN BY: E.C./H.A.G.
 CHECKED BY: G.H.D./E.D.C.
 APPROVED BY: S.M.B./R.F.F.
 DATE: 10-31-06

STUDENT SERVICES CENTER, GULF COAST COMMUNITY COLLEGE

BREL PHAME POYNIER & HOUSER
 ARCHITECTS - ENGINEERS, INC. Tallahassee, FL
 IN ASSOCIATION WITH:
 SMITH BOZARTH FULLER
 ARCHITECTS & PLANNERS, P.A. Panama City, FL

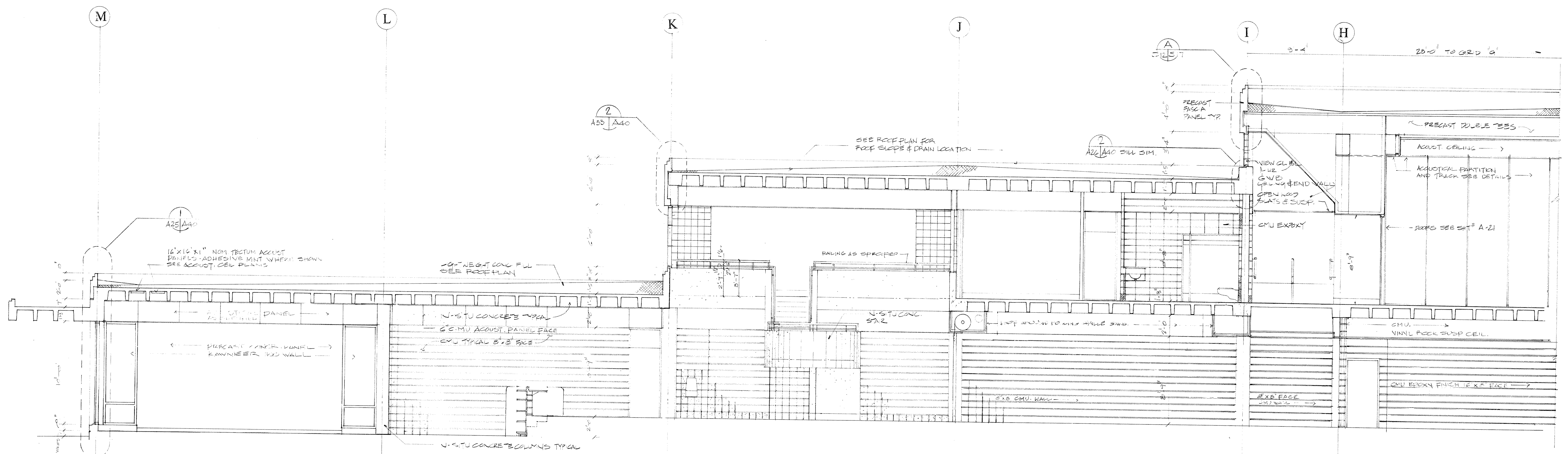

Section

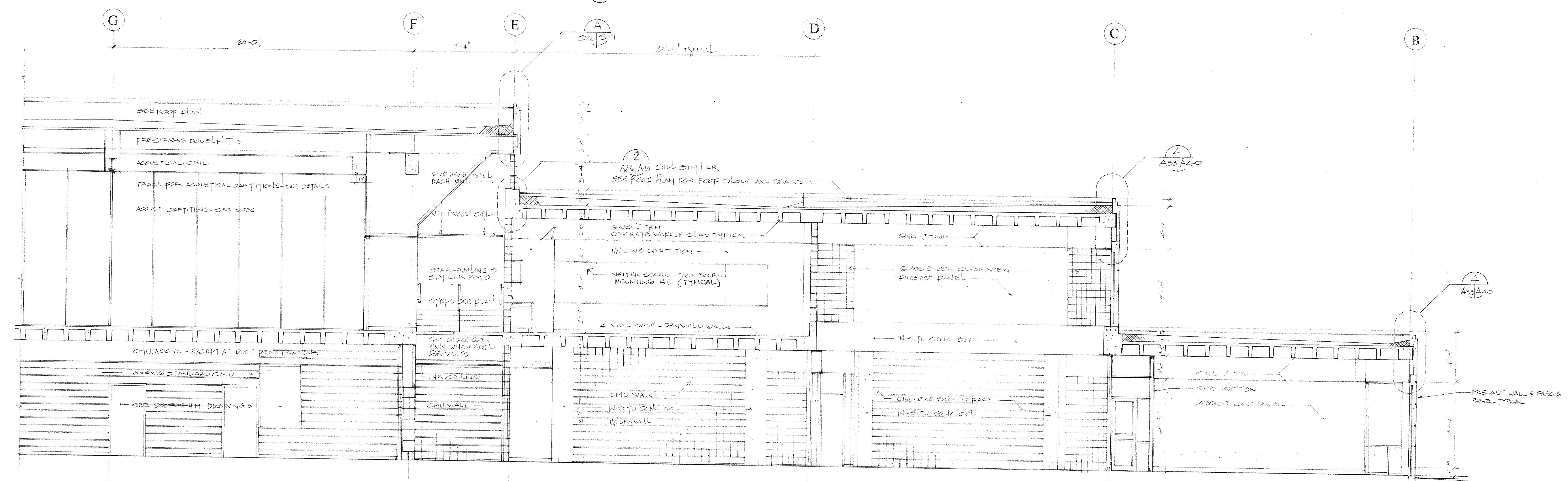

Section Continued

NO.	DATE	REVISION	BY	CHK

DESIGN: P.O. /
 DRAWN: P.O. /
 CHECKED: P.O. /
 APPROVED: P.O. /
 DATE: 12-31-88

STUDENT SERVICES CENTER, GULF COAST COMMUNITY COLLEGE

BRIEL RHAME POYNTER & HOUSER
 ARCHITECTS - ENGINEERS, INC. Tallahassee, FL
 IN ASSOCIATION WITH
 SMITH BOZARTH FULLER
 ARCHITECTS & PLANNERS, P.A. Panama City, FL

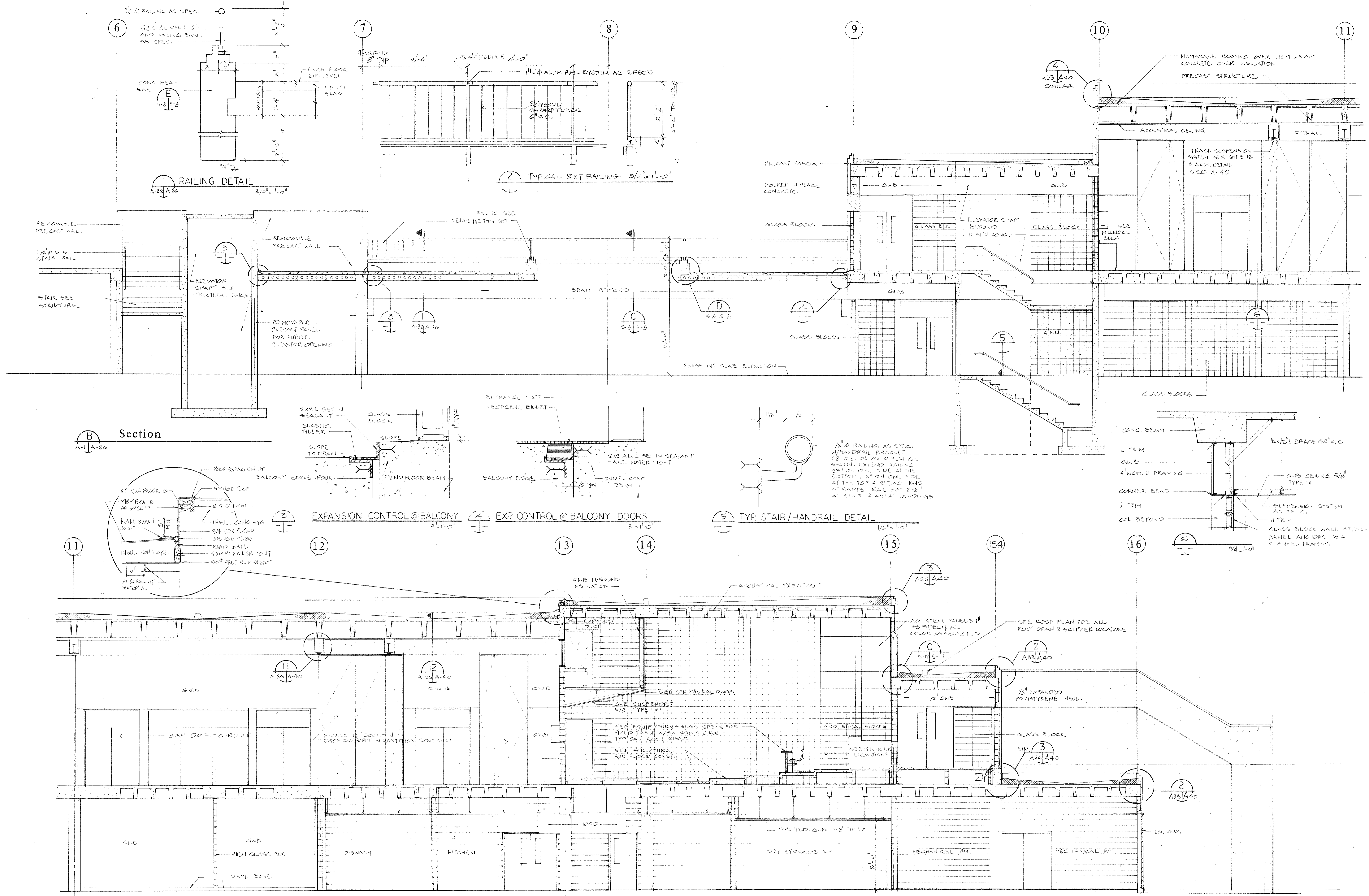

Section Continued

NO.	DATE	REVISION	BY	CHK

DESIGN: P.D.G.
 DRAWN: B.C./E.S.
 CHECKED: E.L.
 APPROVED: J.P.C.
 DATE: 12/31/82

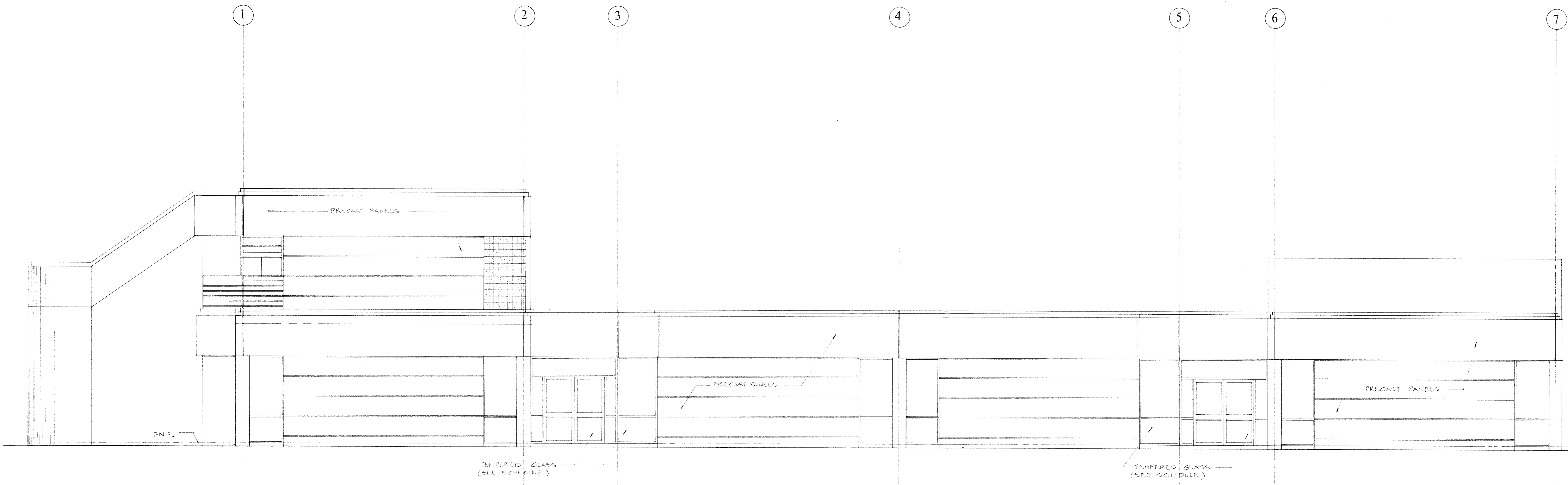

South Elevation (West Building)

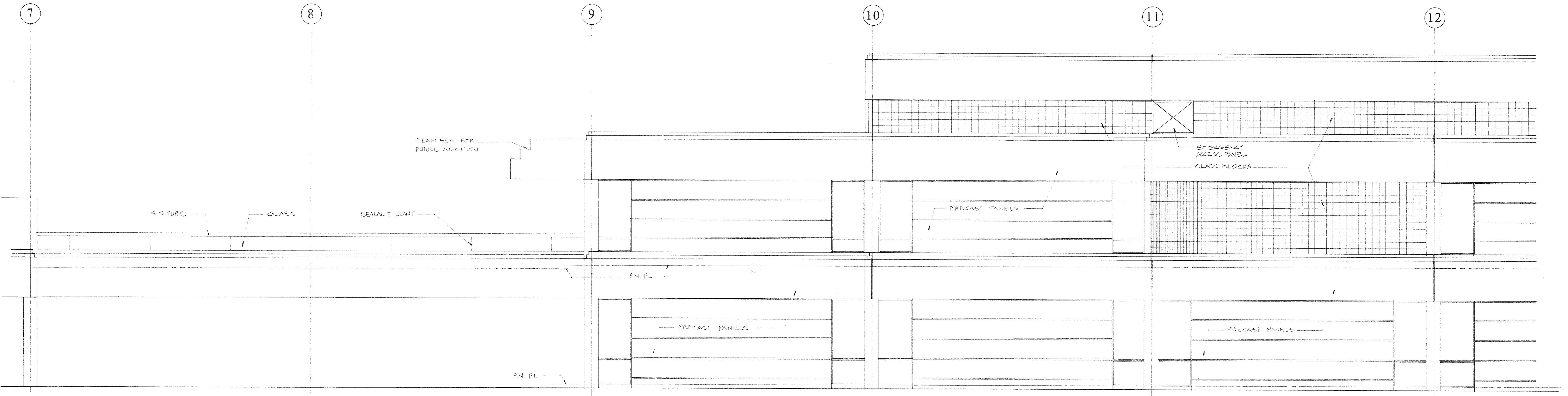

South Elevation (East Building)

NO.	DATE	REVISION	BY	CHK

DESG. EDC. _____
 DRAWN E.S. _____
 CHKD. EDC. _____
 APPR. E.D.E. _____
 DATE: 10-31-95

BRIEL RHAME POYNIER & HOUSER
 ARCHITECTS - ENGINEERS, INC.
 Tallahassee, FL
 IN ASSOCIATION WITH
 SMITH BOZARTH FULLER
 ARCHITECTS & PLANNERS, P.A.
 Panama City, FL
 STUDENT SERVICES CENTER, GULF COAST COMMUNITY COLLEGE

BRIEL RHAME POYNIER & HOUSER
 ARCHITECTS - ENGINEERS, INC.
 Tallahassee, FL
 IN ASSOCIATION WITH
 SMITH BOZARTH FULLER
 ARCHITECTS & PLANNERS, P.A.
 Panama City, FL

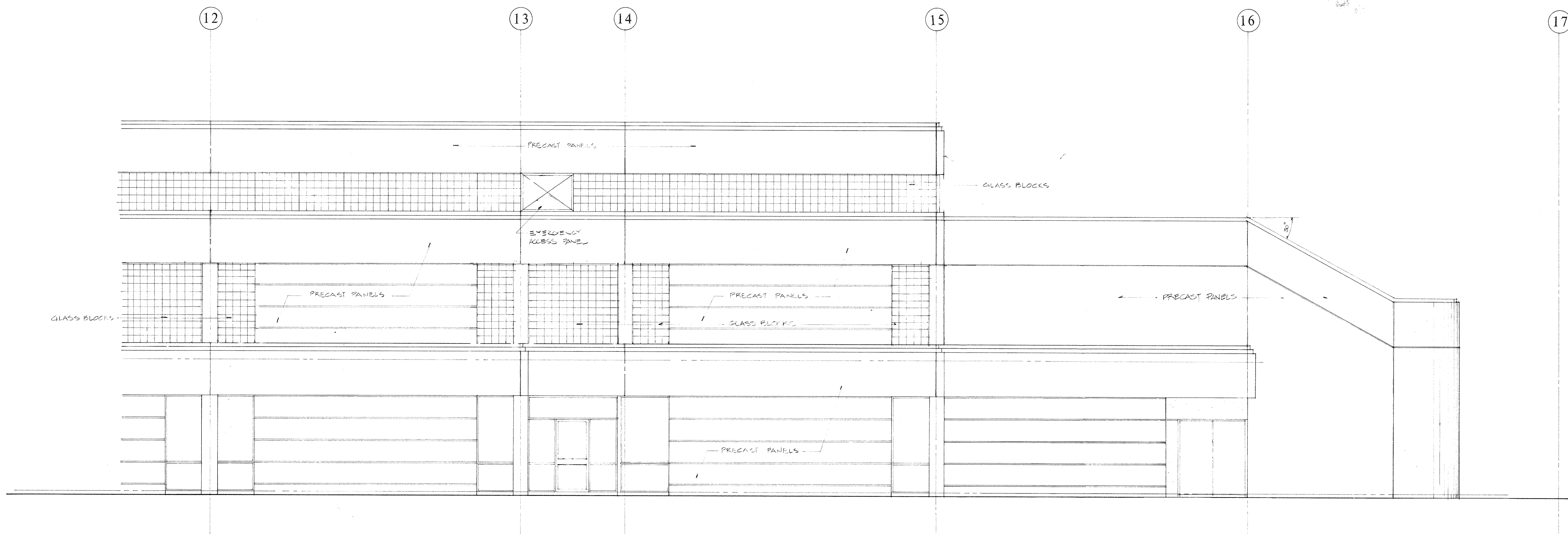

South Elevation (East Building)

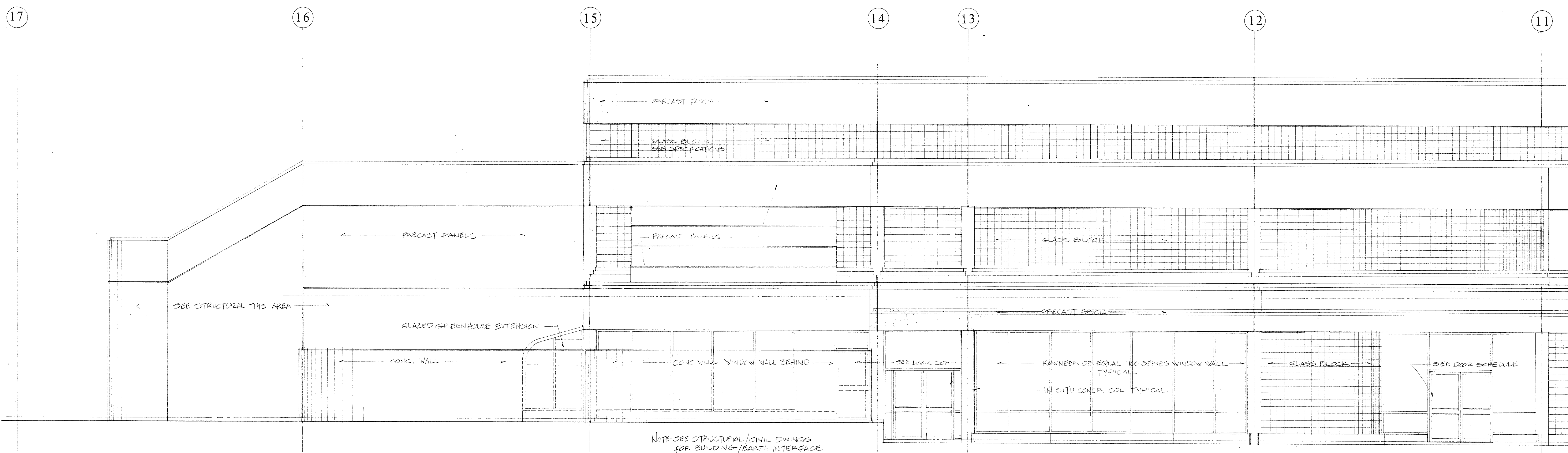

North Elevation (East Building)

NO.	DATE	REVISION	BY	CHK

DESIGNER: E.P.O.
 DRAWN: E.S./R.C.C.
 CHECKED: J.E.D.C.
 APPROVED: J.E.D.C.
 DATE: 12-31-02

STUDENT SERVICES CENTER, GULF COAST COMMUNITY COLLEGE

BRIEL RHAME FOYNIER & HOUSER
 ARCHITECTS - ENGINEERS, INC.
 IN ASSOCIATION WITH
 SMITH BOZARTH FULLER
 ARCHITECTS & PLANNERS, P.A.
 Tallahassee, FL
 Panama City, FL

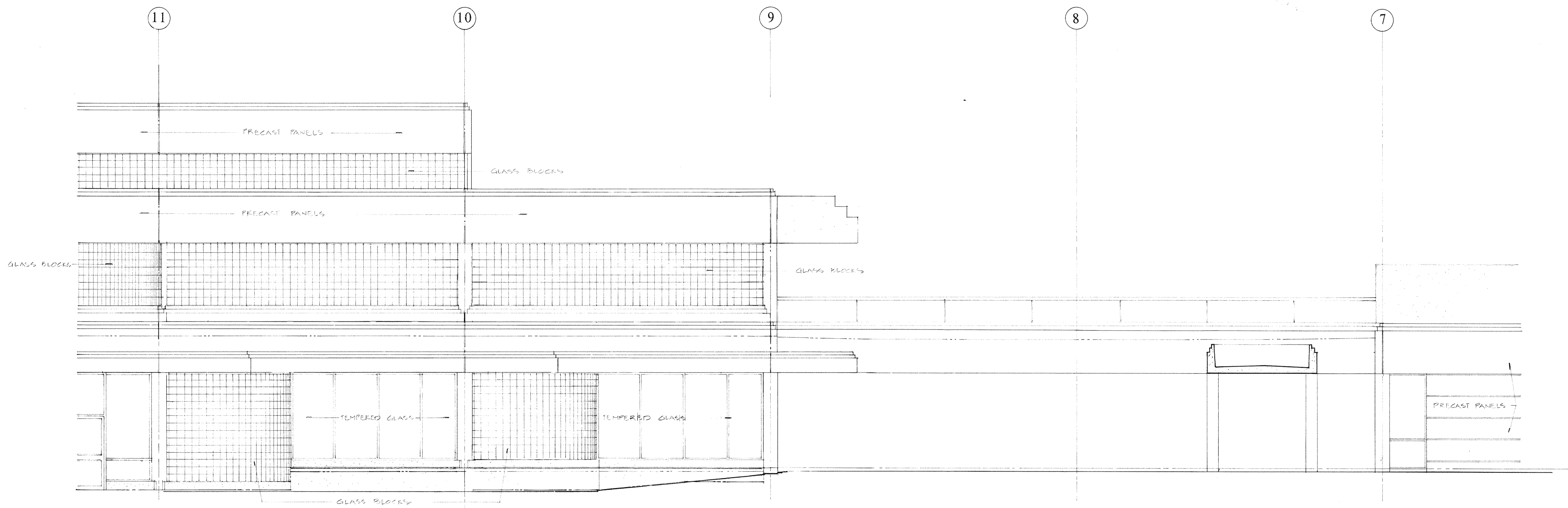

North Elevation (East Building)

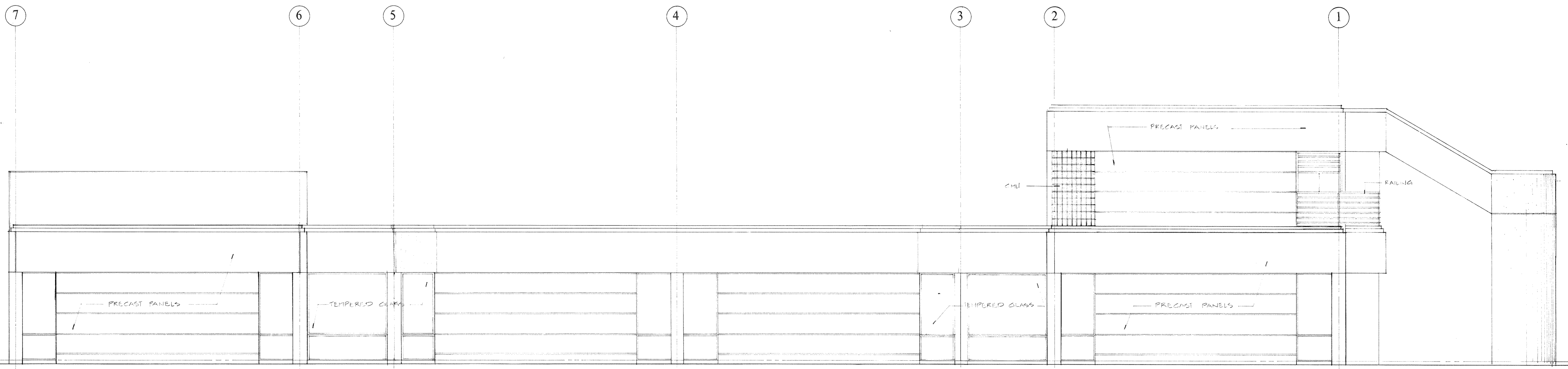

North Elevation (West Building)

NO.	DATE	REVISION	BY	CHK

DESIG. E.D.C.	BY	CHK
DRAWN E.S.	CHKD	E.D.C.
APPR. E.D.C.	DATE	12/31/25

BRIEL RHAME POYNTER & HOUSER
 ARCHITECTS - ENGINEERS, INC.
 TALLAHASSEE, FL
 IN ASSOCIATION WITH
 SMITH BOZARTH FULLER
 ARCHITECTS & PLANNERS, P.A.
 PANAMA CITY, FL
 STUDENT SERVICES CENTER, GULF COAST COMMUNITY COLLEGE

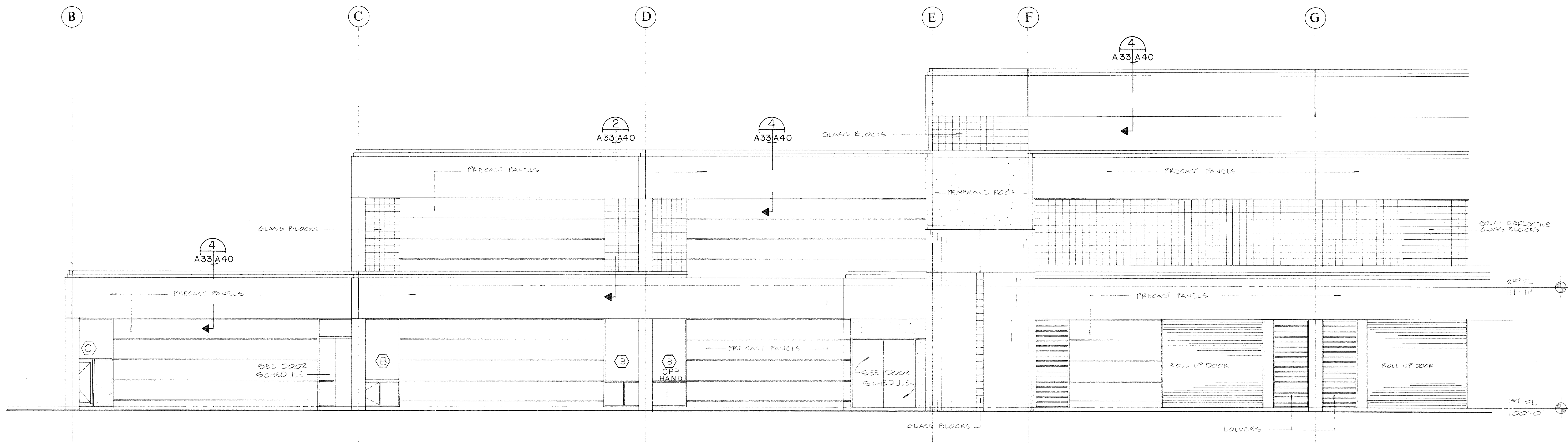

East Elevation (East Building)

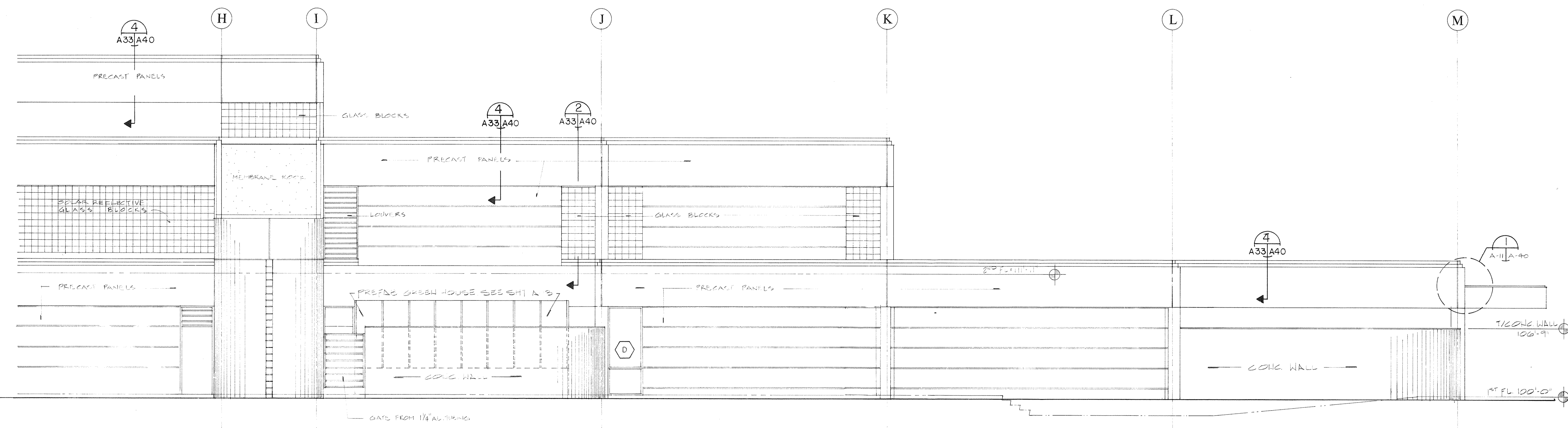

East Elevation (East Building)

NO.	DATE	REVISION	BY	CHK

DESG. RDC
 DRAWN R.S./JAG
 CHD. RDC
 APPR. J.E.C.
 DATE 07-21-88

STUDENT SERVICES CENTER, GULF COAST COMMUNITY COLLEGE

BRIEL RHAME POYNTER & HOUSER
 ARCHITECTS - ENGINEERS, INC.
 IN ASSOCIATION WITH
 SMITH BOZARTH FULLER
 ARCHITECTS & PLANNERS, P.A.
 Tallahassee, FL
 Panama City, FL

JOB NO. 1857.02
 SHEET A-30

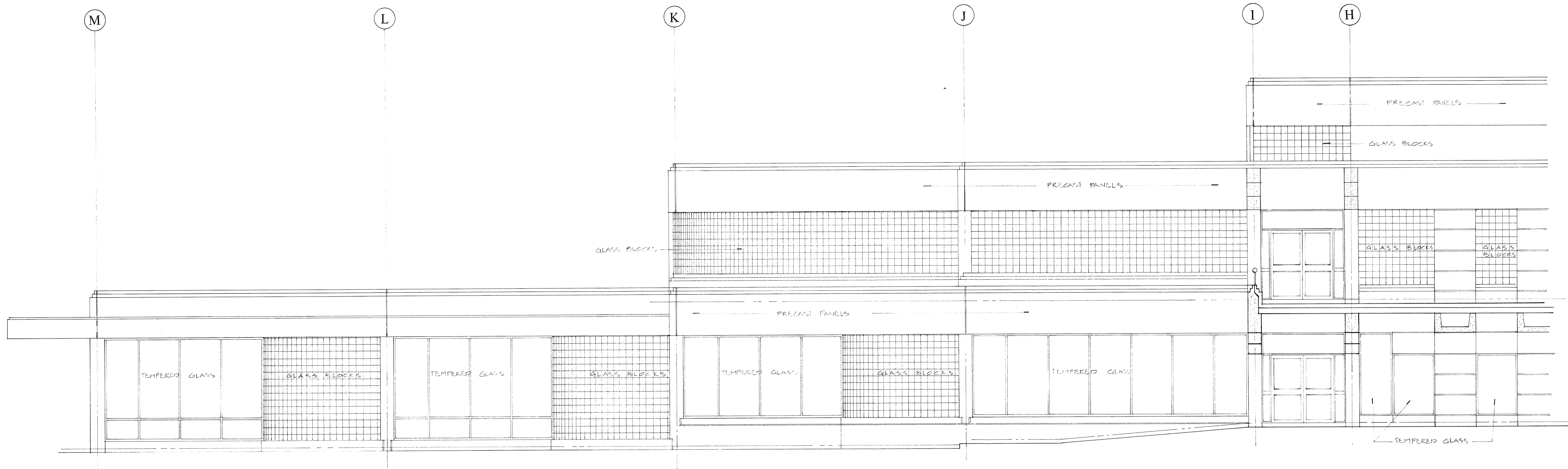

West Elevation (East Building)

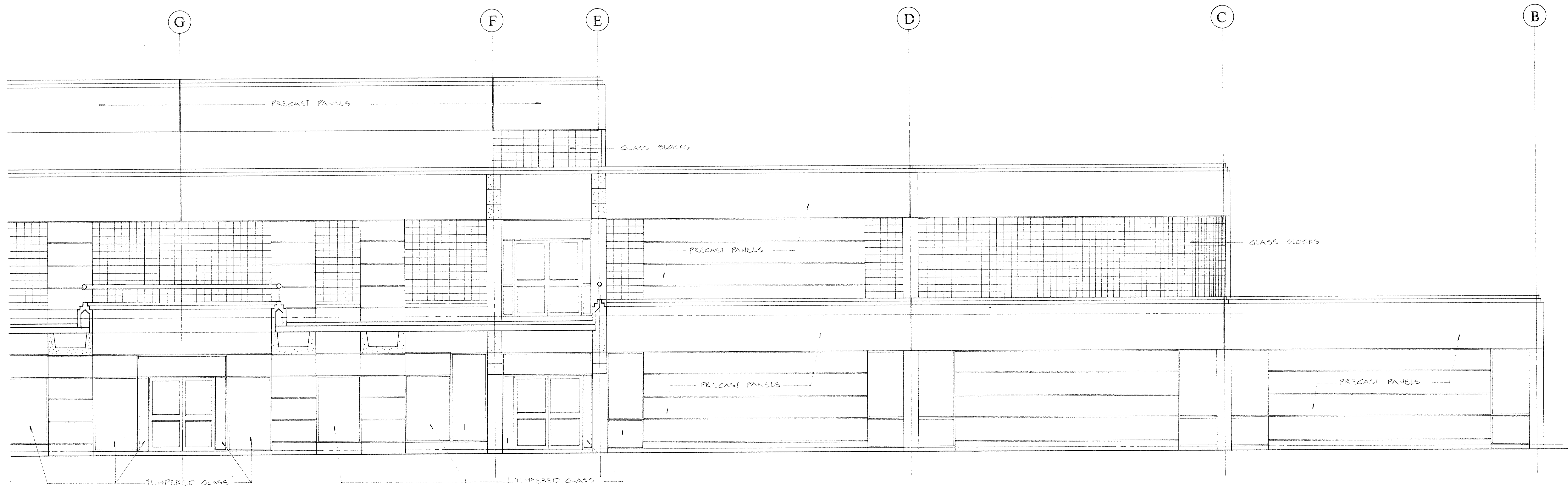

West Elevation (East Building)

NO.	DATE	REVISION	BY	CHK.

DESIG. E.P.C.	
DRAWN E.S.	
CHECK E.P.C.	
APPV. E.P.C.	
DATE 12-21-25	

STUDENT SERVICES CENTER, GULF COAST COMMUNITY COLLEGE

BD/EL RHAME POYNTER & HOUSER
 ARCHITECTS-ENGINEERS, INC. Tallahassee, FL
 IN ASSOCIATION WITH
 SMITH BOZARTH FULLER
 ARCHITECTS & PLANNERS, P.A. Panama City, FL

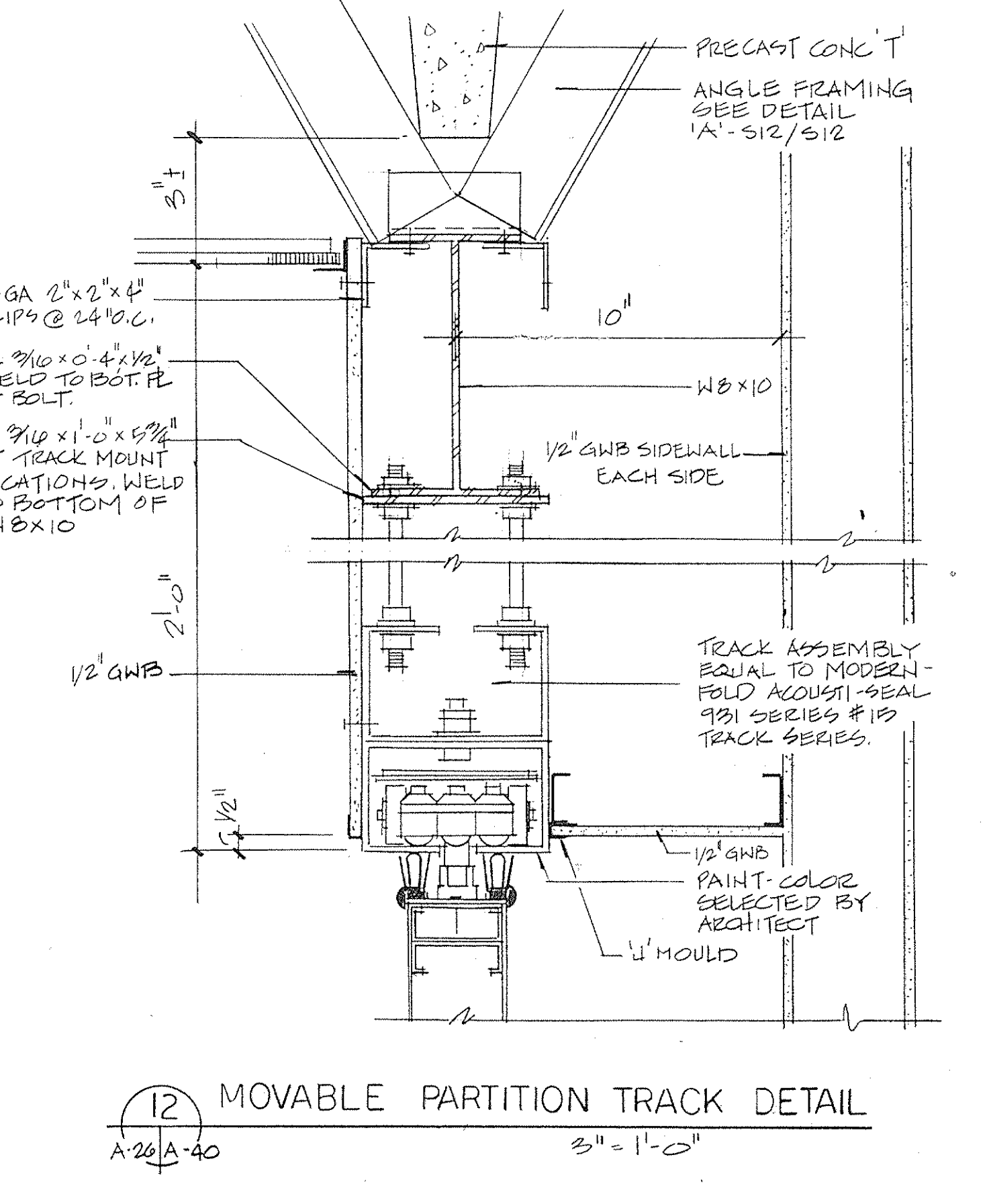
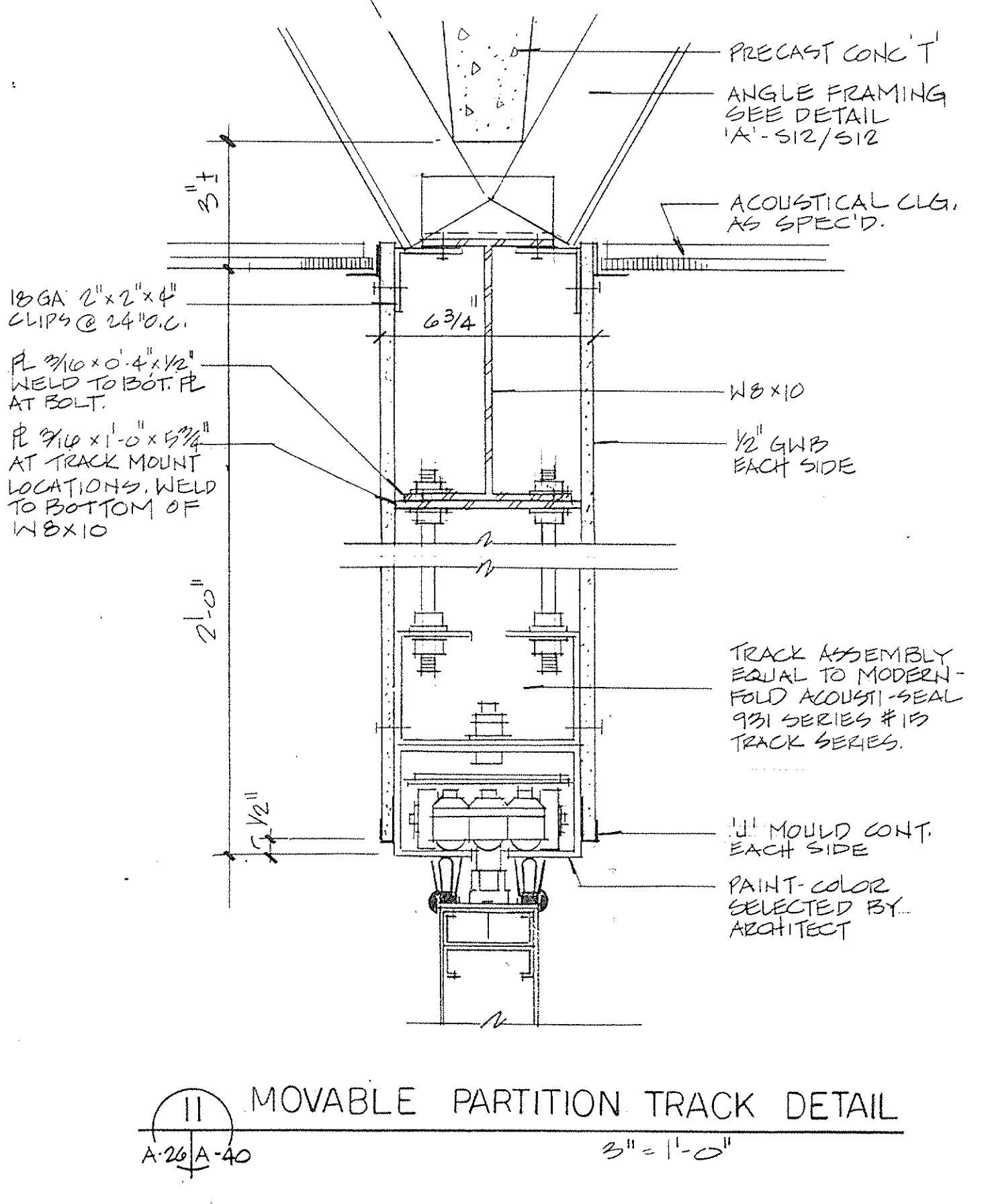
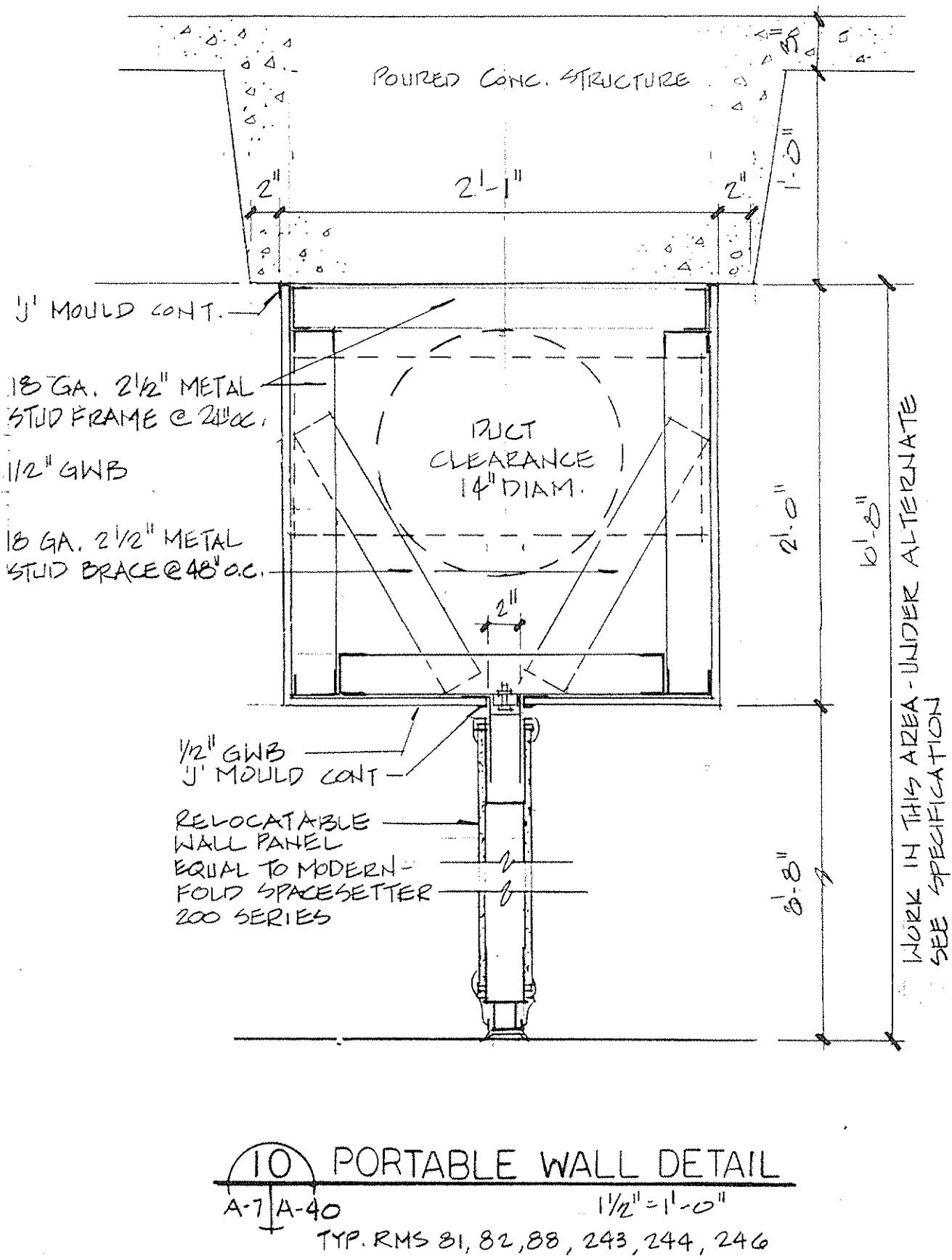
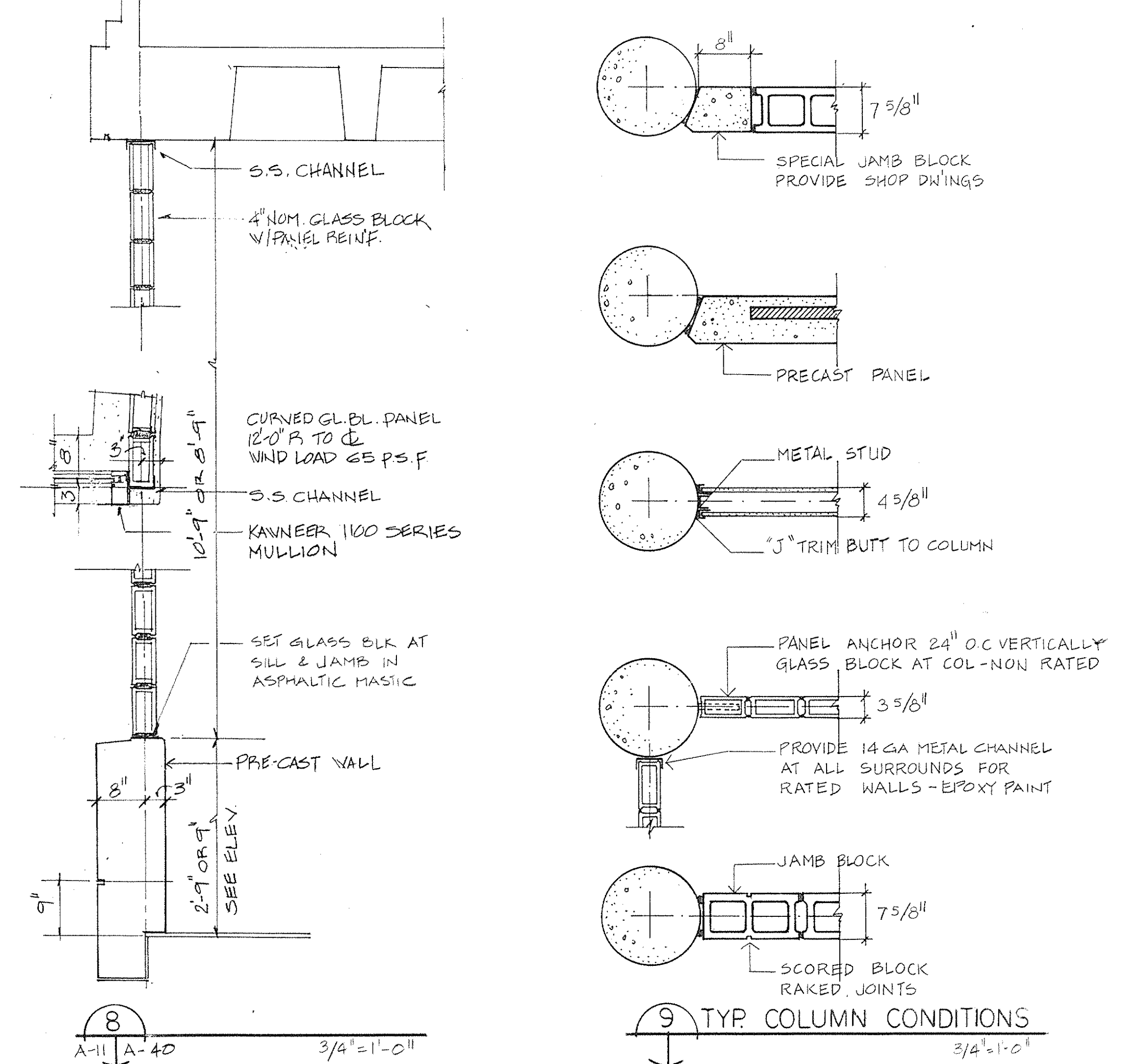
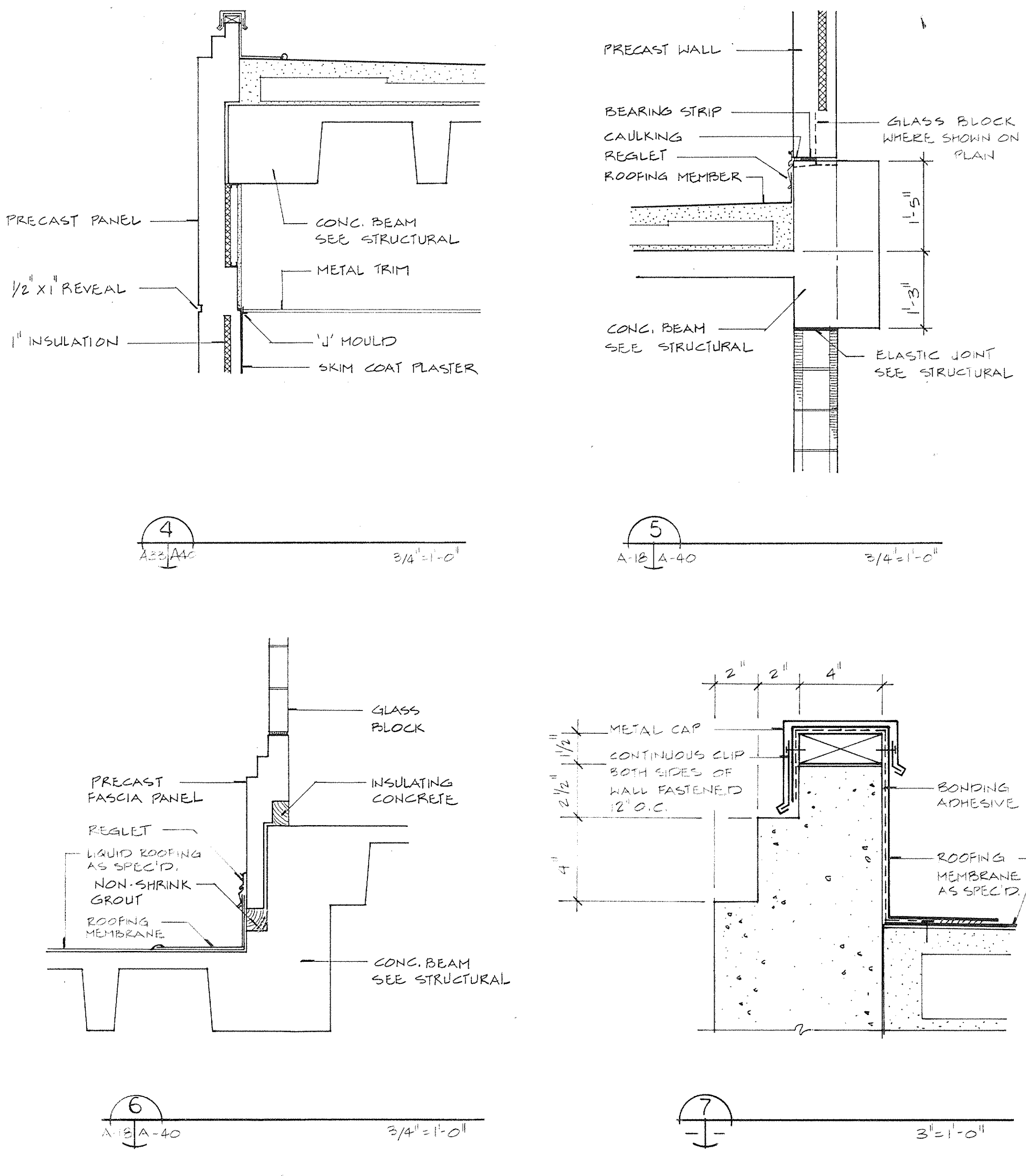
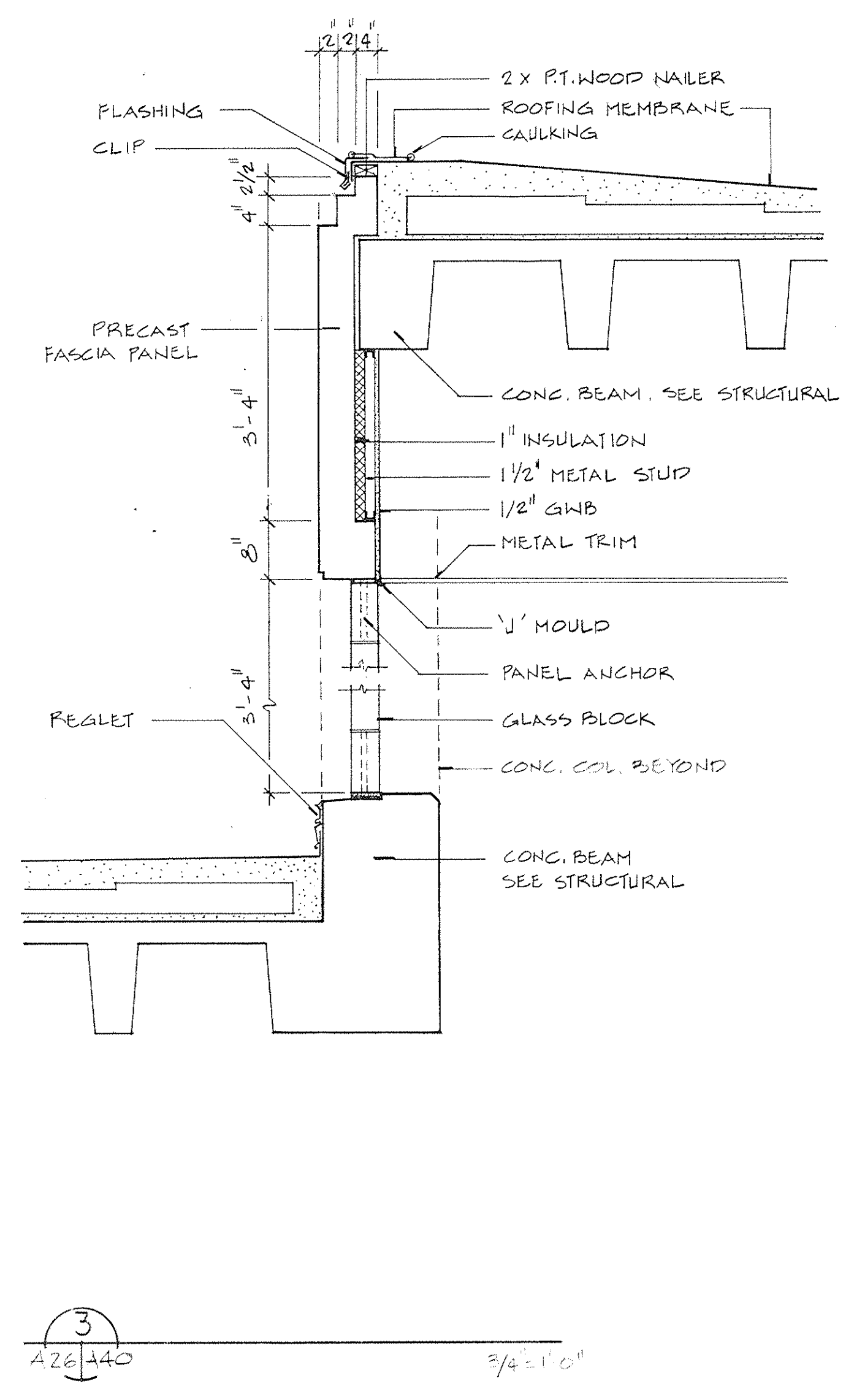
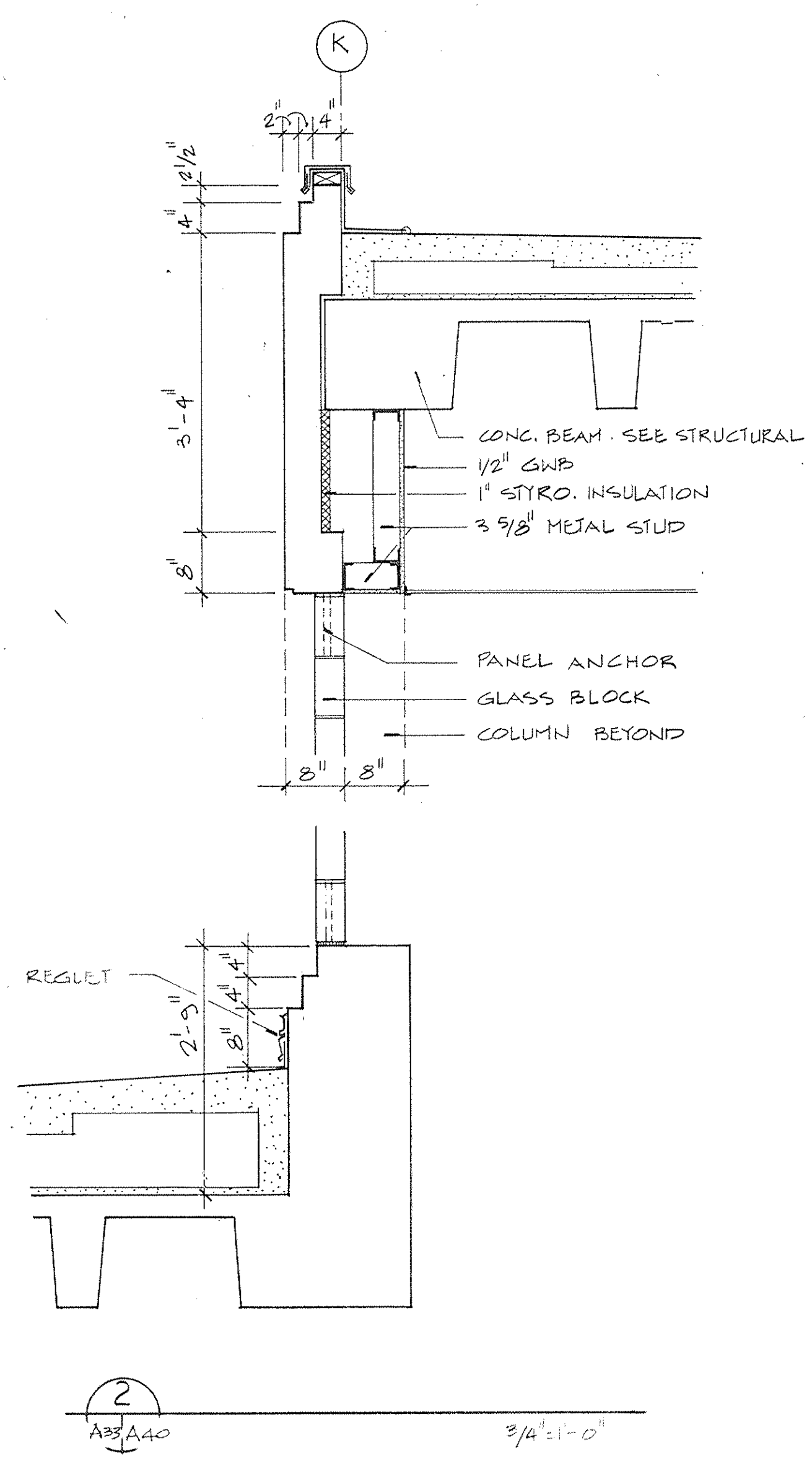
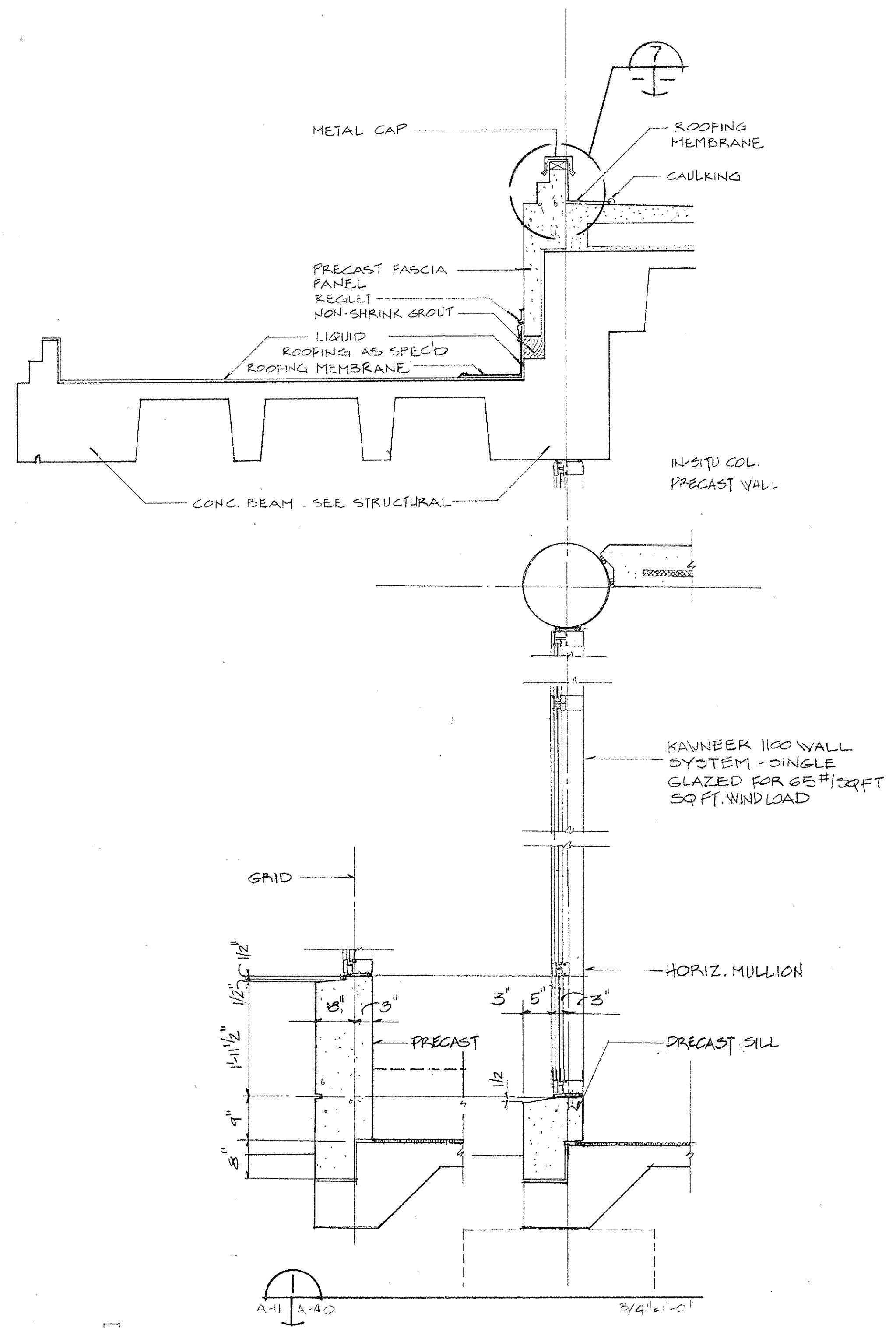

REV.	DATE	REVISION

MENG. REC.
 DRAW. REV.
 CHECK E.D.C.
 APPRO. E.D.C.
 DATE: 10-31-88

STUDENT SERVICES CENTER, GULF COAST COMMUNITY COLLEGE

BRIEL RAME POYNTER & HOUSER
 ARCHITECTS - ENGINEERS, INC. Tallahassee, FL
 IN ASSOCIATION WITH
 SMITH BOZARTH FULLER
 ARCHITECTS & PLANNERS, P.A. Panama City, FL

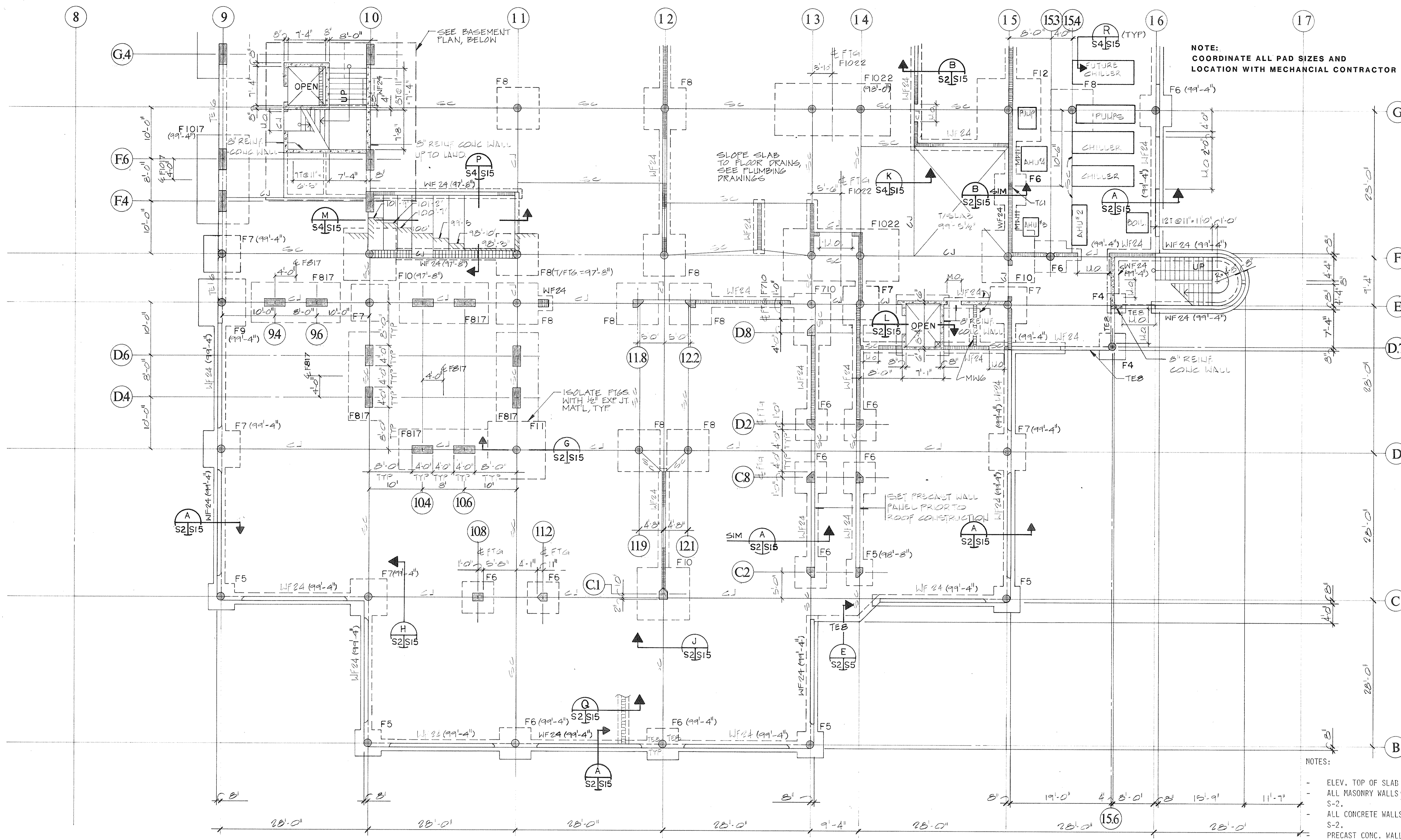

NOTE:
COORDINATE ALL PAD SIZES AND
LOCATION WITH MECHANICAL CONTRACTOR

- NOTES:
- ELEV. TOP OF SLAB = 100'-0" (ACTUAL EL = 12.25') U.O.N.
 - ALL MASONRY WALLS [] TYPE MW1 U.O.N., SEE SCH. SHT S-2.
 - ALL CONCRETE WALLS [] TYPE W1 U.O.N., SEE SCH. SHT S-2.
 - PRECAST CONC. WALLS [] TYPICAL
 - ALL 4" CMU & GLASS BLOCK WALLS (NOT SHOWN FOR CLARITY, SEE ARCH. DWGS.) TO BE FOUNDED ON THICKENED SLAB AS INDICATED IN SECTION "Q/S2/S15".
 - FOOTING SCHEDULE, SEE SHEET S-2.
 - CONC. BEAM SCHEDULE, SEE SHEET S-19.
 - CONC. COLUMN SCHEDULE, SEE SHEET S-18.
 - SLOPE SLAB TO FLOOR DRAINS, SEE PLUMBING DWGS. FOR LOCATIONS.
 - SLAB ON GRADE SHALL BE 4" THICK WITH 6X6 - W1.4 X W1.4 W/F ON CURING BARRIER ON COMPACTED SUBGRADE, U.O.N.

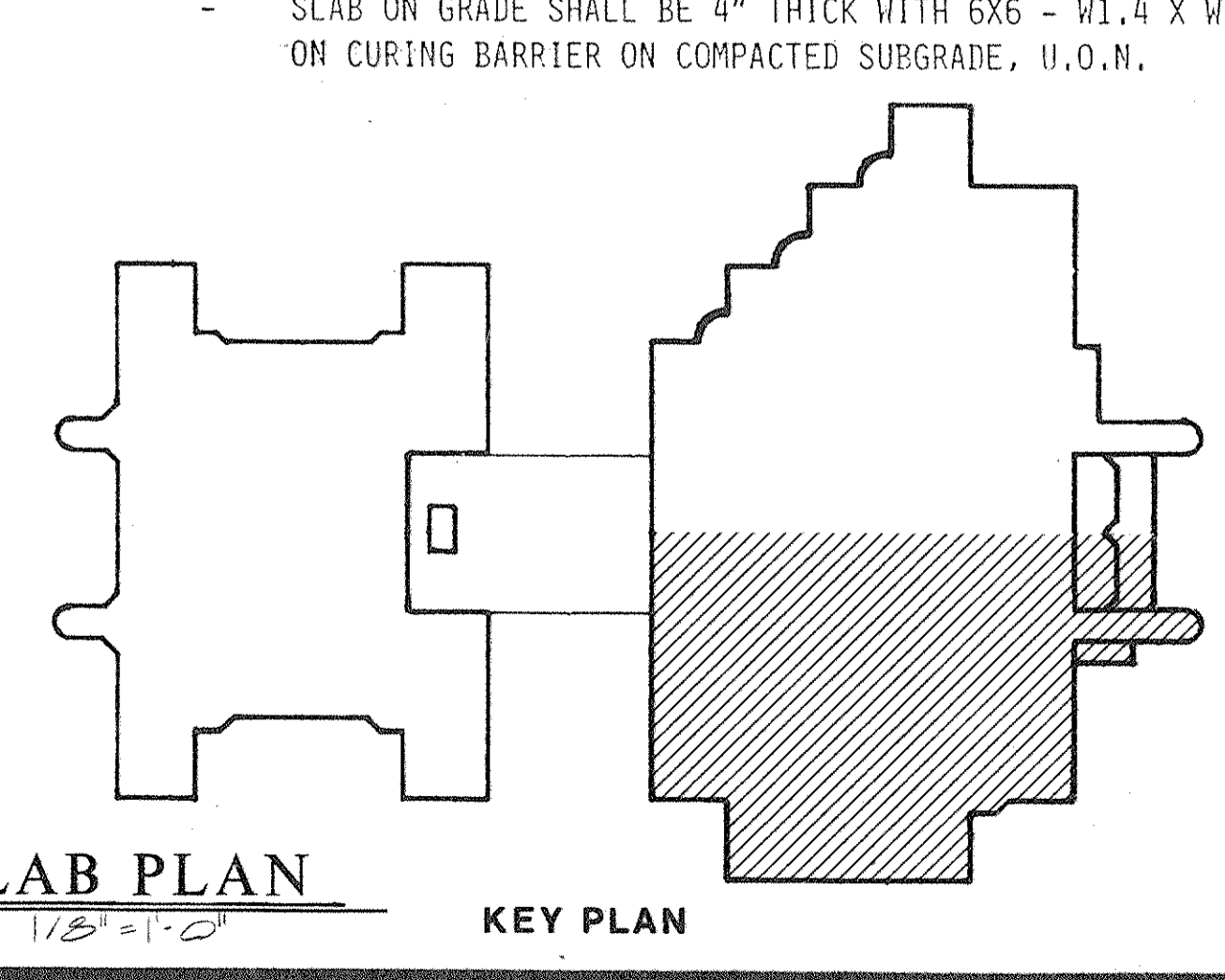
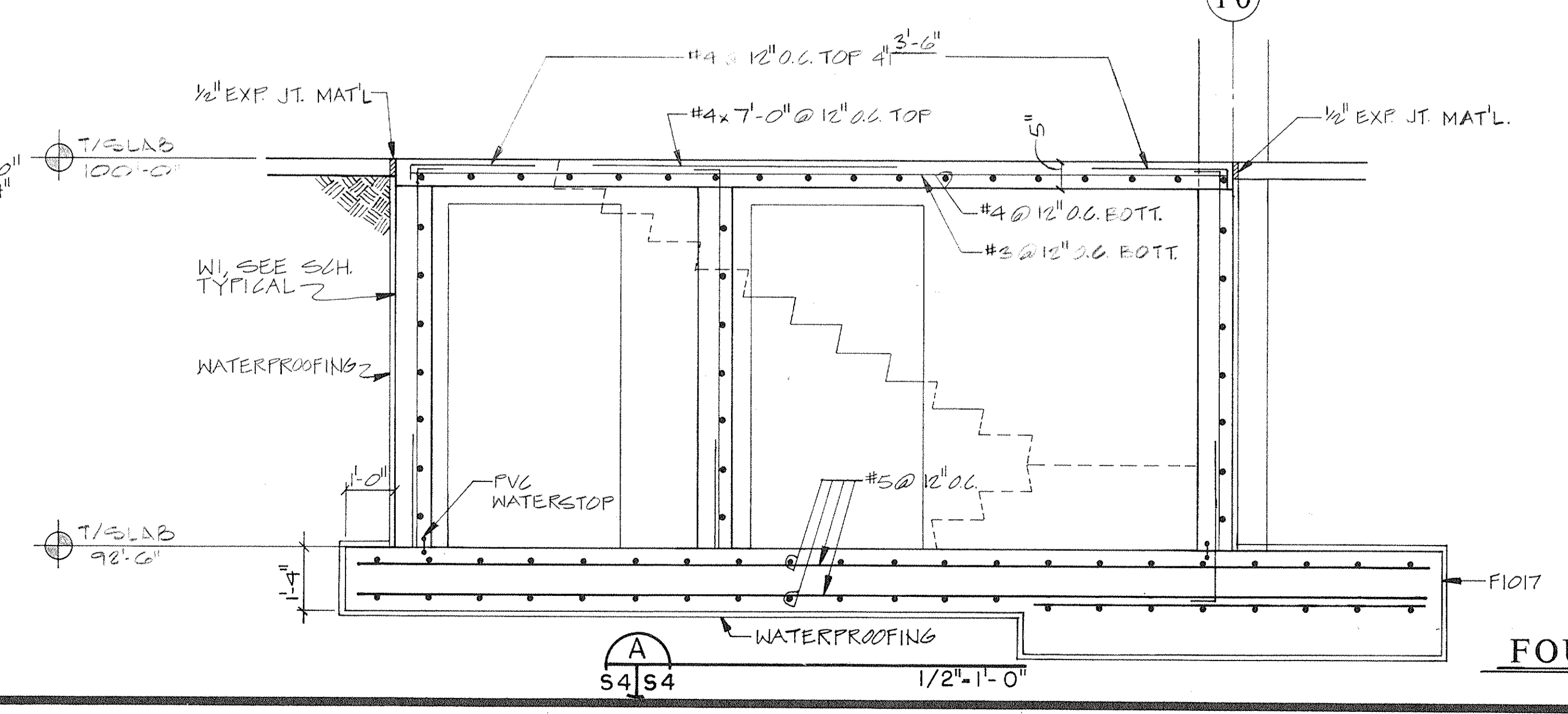
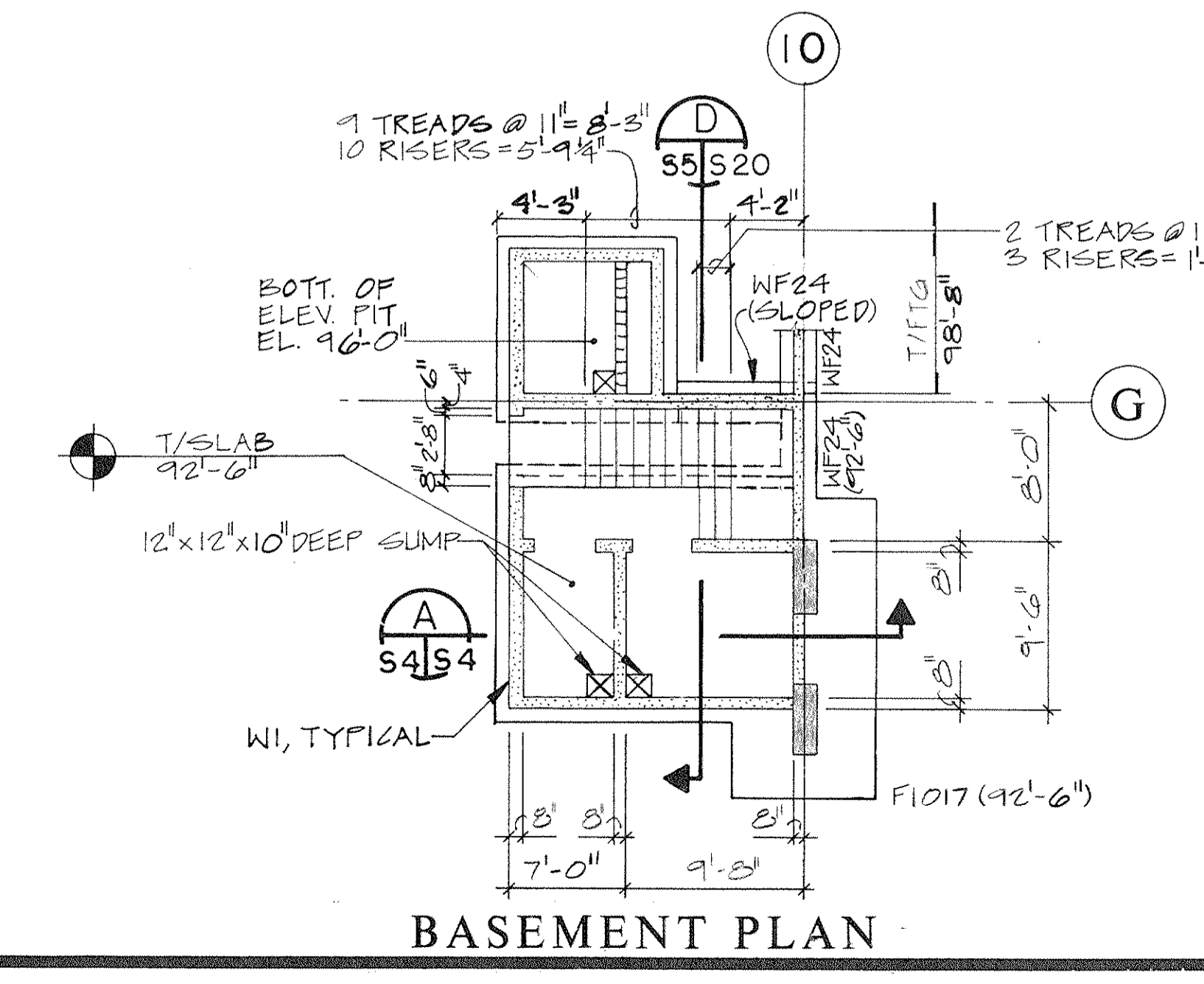

STUDENT SERVICES "SOUTH" FOUNDATION & SLAB PLAN

NO.	DATE	REVISION	BY	CHKD.

AHM WAG RBL
 ARCHITECTS - ENGINEERS, INC.
 TALLAHASSEE, FL
 SMITH BOZARTH FULLER
 ARCHITECTS & PLANNERS, P.A.
 PANAMA CITY, FL

JOB NO. 735702
 SHEET S-4
 74 OF 155

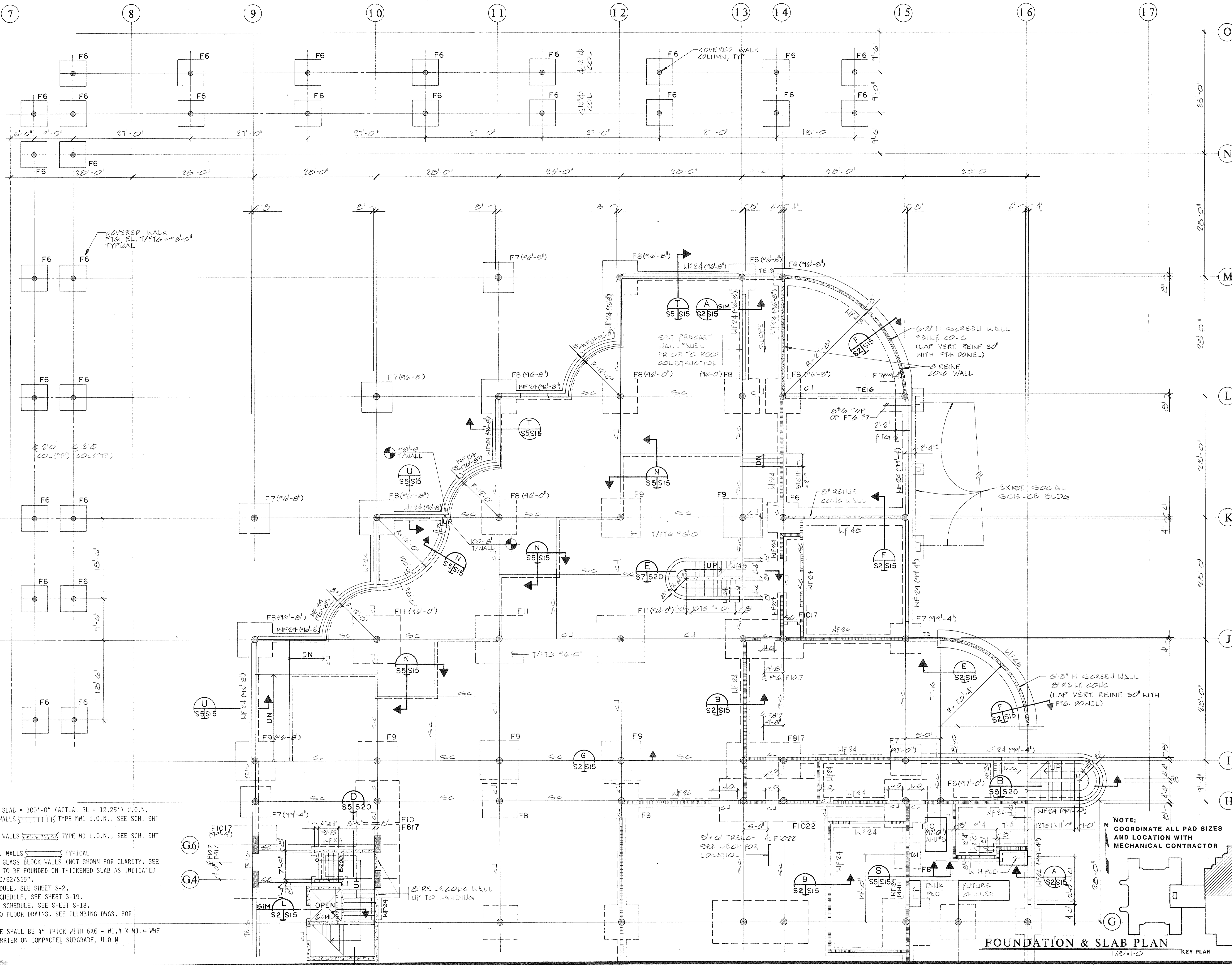

- NOTES:
- ELEV. TOP OF SLAB = 100'-0" (ACTUAL EL. = 12.25') U.O.N.
 - ALL MASONRY WALLS TYPE MW1 U.O.N., SEE SCH. SHT S-2.
 - ALL CONCRETE WALLS TYPE W1 U.O.N., SEE SCH. SHT S-2.
 - PRECAST CONC. WALLS TYPE TYPICAL
 - ALL 4" CMU & GLASS BLOCK WALLS (NOT SHOWN FOR CLARITY, SEE ARCH. DWGS.) TO BE FOUND ON THICKENED SLAB AS INDICATED IN SECTION "Q/S2/S15".
 - FOOTING SCHEDULE, SEE SHEET S-2.
 - CONC. BEAM SCHEDULE, SEE SHEET S-19.
 - CONC. COLUMN SCHEDULE, SEE SHEET S-18.
 - SLOPE SLAB TO FLOOR DRAINS, SEE PLUMBING DWGS. FOR LOCATIONS.
 - SLAB ON GRADE SHALL BE 4" THICK WITH 6X6 - W1.4 X W1.4 W/F ON CURING BARRIER ON COMPACTED SUBGRADE, U.O.N.

NOTE:
COORDINATE ALL PAD SIZES AND LOCATION WITH MECHANICAL CONTRACTOR

FOUNDATION & SLAB PLAN
1/8"=1'-0" KEY PLAN

STUDENT SERVICES "NORTH" FOUNDATION & SLAB PLAN

NO.	DATE	REVISION	BY	CHK

DESIGN: AHM
DRAWN: MAG
CHECKED: RBL
APPROVED: RBL
DATE: 10-31-88

STUDENT SERVICES CENTER, GULF COAST COMMUNITY COLLEGE

BRIEL RHAME POYNTER & HOUSER
ARCHITECTS - ENGINEERS, INC., Tallahassee, FL
IN ASSOCIATION WITH
SMITH BOZARTH FULLER
ARCHITECTS & PLANNERS, PA.
Panama City, FL

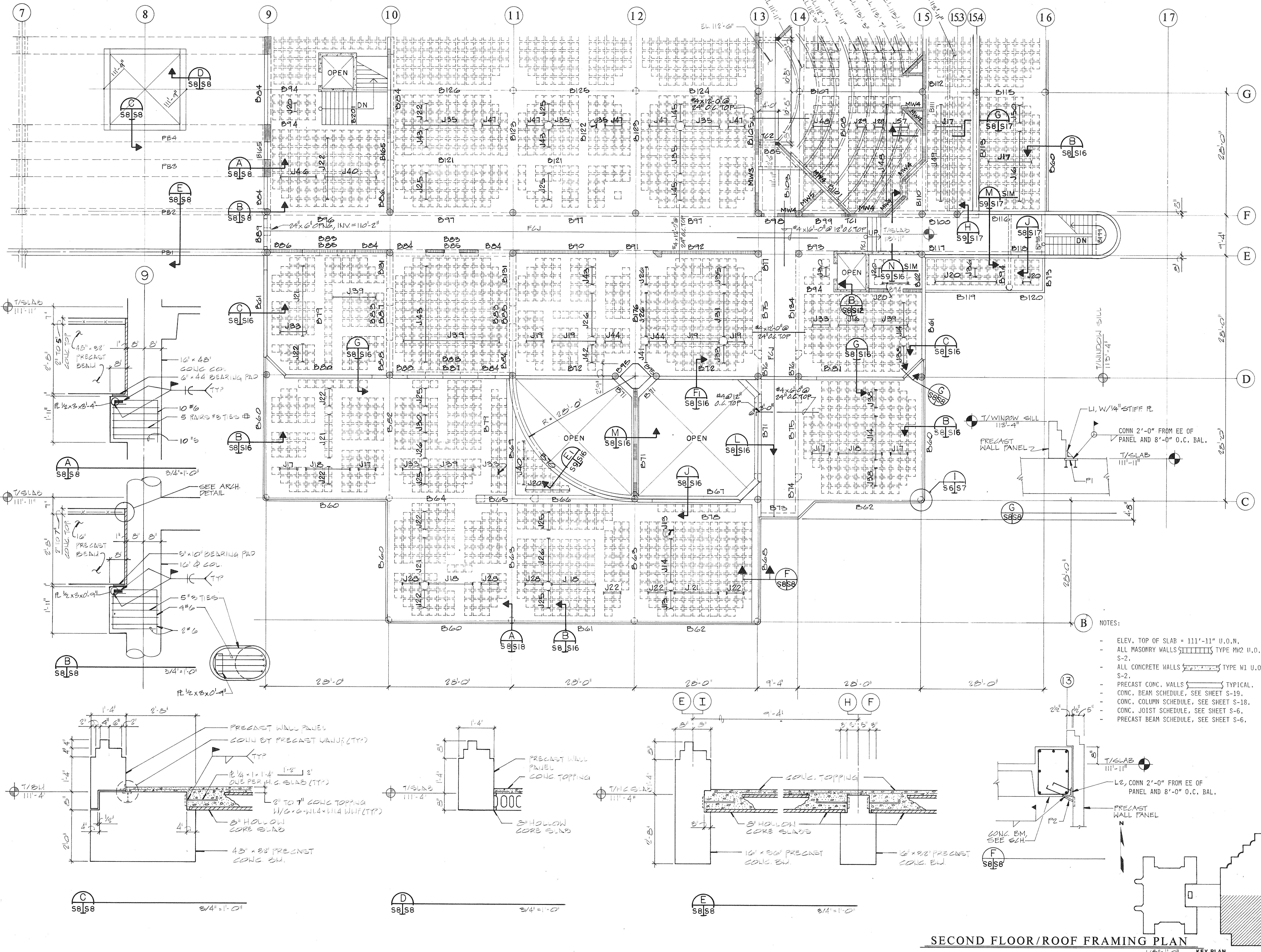

- NOTES:
- ELEV. TOP OF SLAB = 111'-11" U.O.N.
 - ALL MASONRY WALLS [Symbol] TYPE M2 U.O.N., SEE SCH. SHT S-2.
 - ALL CONCRETE WALLS [Symbol] TYPE W1 U.O.N., SEE SCH. SHT S-2.
 - PRECAST CONC. WALLS [Symbol] TYPICAL.
 - CONC. BEAM SCHEDULE, SEE SHEET S-19.
 - CONC. COLUMN SCHEDULE, SEE SHEET S-18.
 - CONC. JOIST SCHEDULE, SEE SHEET S-6.
 - PRECAST BEAM SCHEDULE, SEE SHEET S-6.

SECOND FLOOR/ROOF FRAMING PLAN

NO.	DATE	REVISION	BY	CHK

DESIGNED BY: **AHM**
 DRAWN BY: **MAG**
 CHECKED BY: **KBG**
 APPROVED BY: **APR**
 DATE: **10-21-88**

STUDENT SERVICES CENTER, GULF COAST COMMUNITY COLLEGE

BRIEL RHAME POYNTER & HOUSER
 ARCHITECTS - ENGINEERS, INC.
 Tallahassee, FL
SMITH BOZARTH FULLER
 ARCHITECTS & PLANNERS, P.A.
 Panama City, FL

JOB NO. 7267.02
 SHEET S-8
 78 OF 155

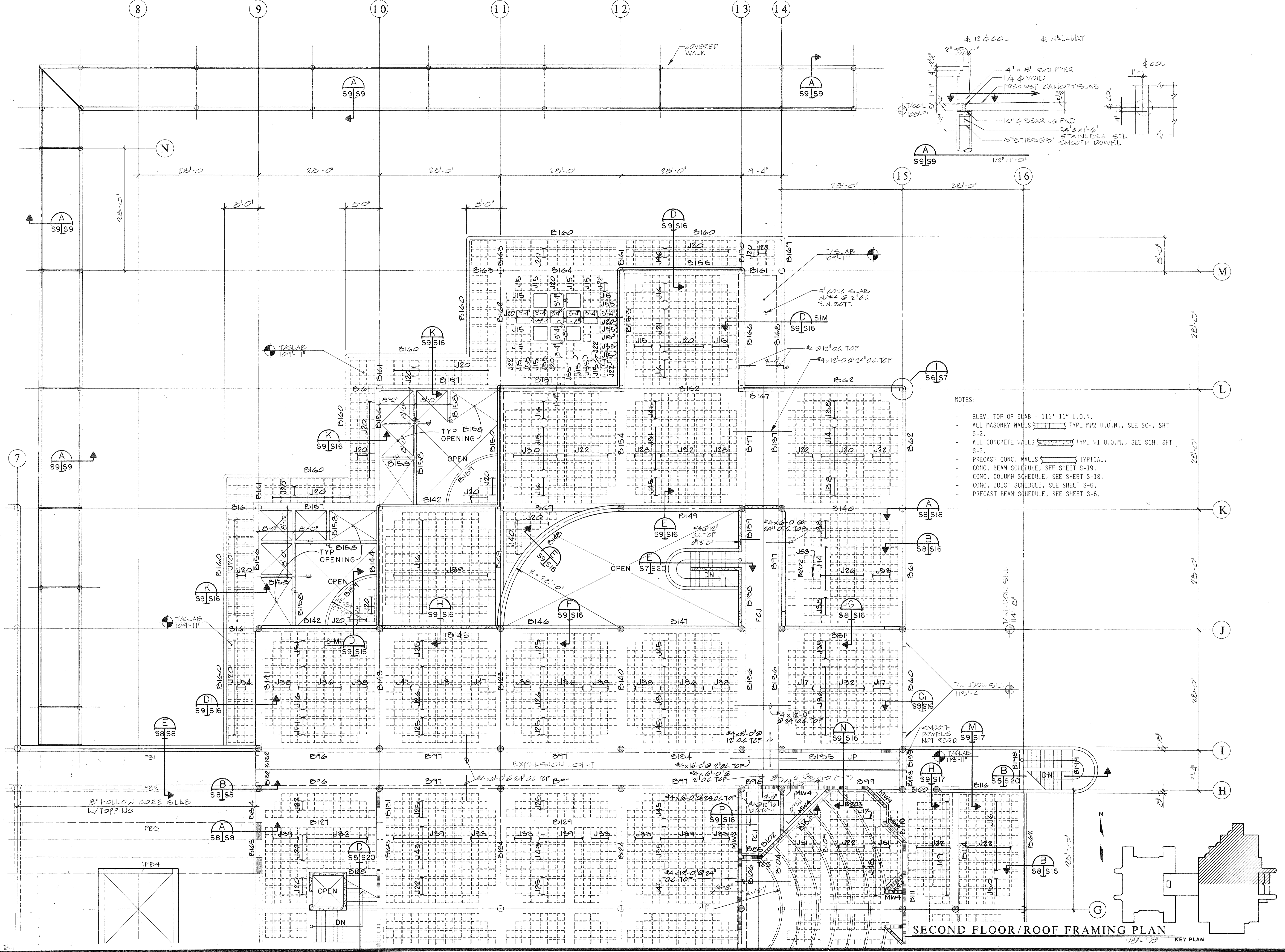

- NOTES:
- ELEV. TOP OF SLAB = 111'-11" U.O.M.
 - ALL MASONRY WALLS [] TYPE MM2 U.O.M., SEE SCH. SHT S-2.
 - ALL CONCRETE WALLS [] TYPE M1 U.O.M., SEE SCH. SHT S-2.
 - PRECAST CONC. WALLS [] TYPICAL.
 - CONC. BEAM SCHEDULE, SEE SHEET S-19.
 - CONC. COLUMN SCHEDULE, SEE SHEET S-18.
 - CONC. JOIST SCHEDULE, SEE SHEET S-6.
 - PRECAST BEAM SCHEDULE, SEE SHEET S-6.

SECOND FLOOR/ROOF FRAMING PLAN

STUDENT SERVICES "NORTH" SECOND FLOOR/ROOF FRAMING PLAN

NO.	DATE	REVISION	BY

REV. AHM
 DRAWN WAG
 CHECK REL
 APP. DATE 10-31-88

BRIEL RHAME POYNTER & HOUSER
 ARCHITECTS - ENGINEERS, INC.
 Tallahassee, FL

IN ASSOCIATION WITH
 SMITH BOZARTH FULLER
 ARCHITECTS & PLANNERS, P.A.
 Panama City, FL

STUDENT SERVICES CENTER, GULF COAST COMMUNITY COLLEGE

JOB NO. 7357.02
 SHEET S-9
 79 OF 155

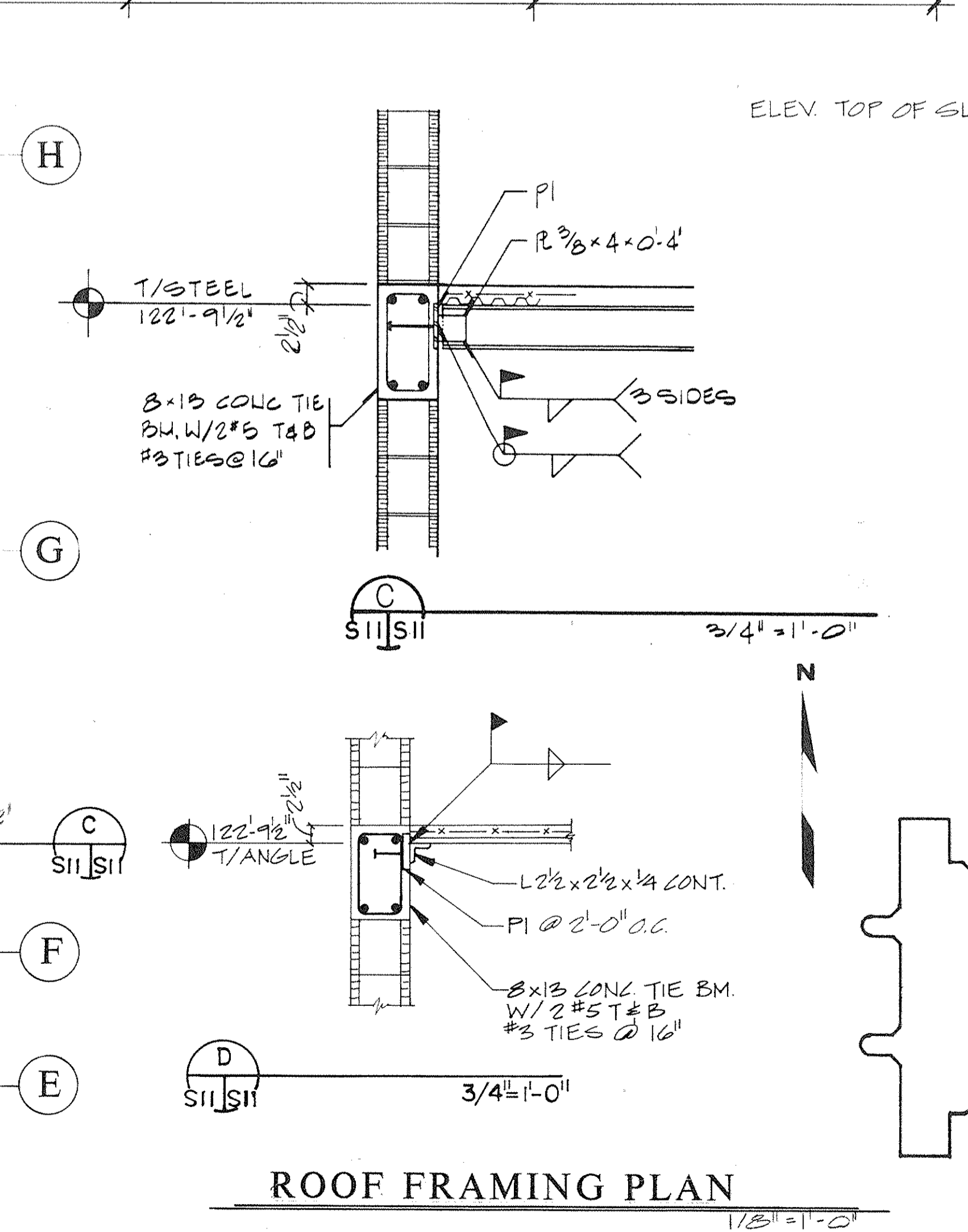
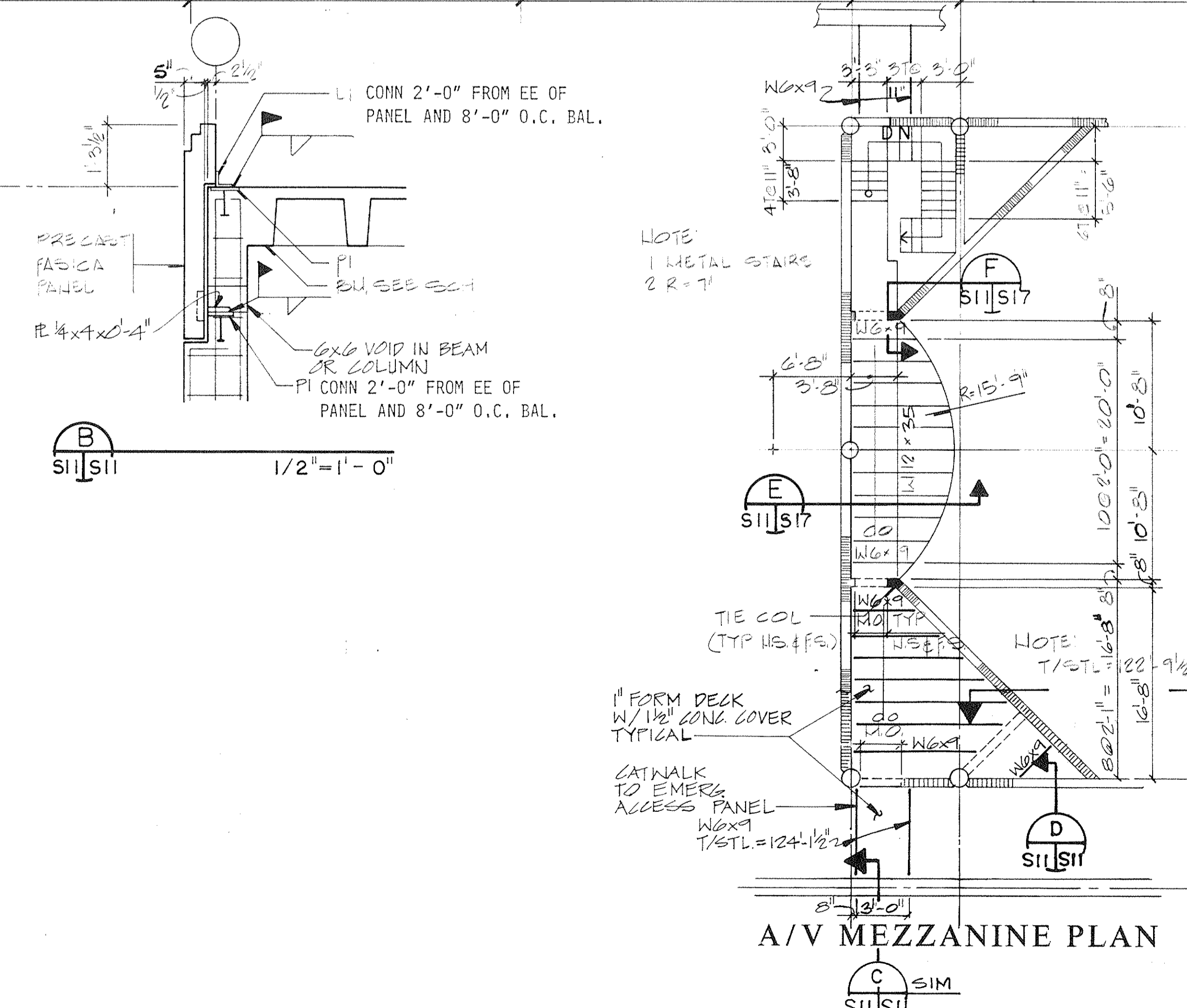
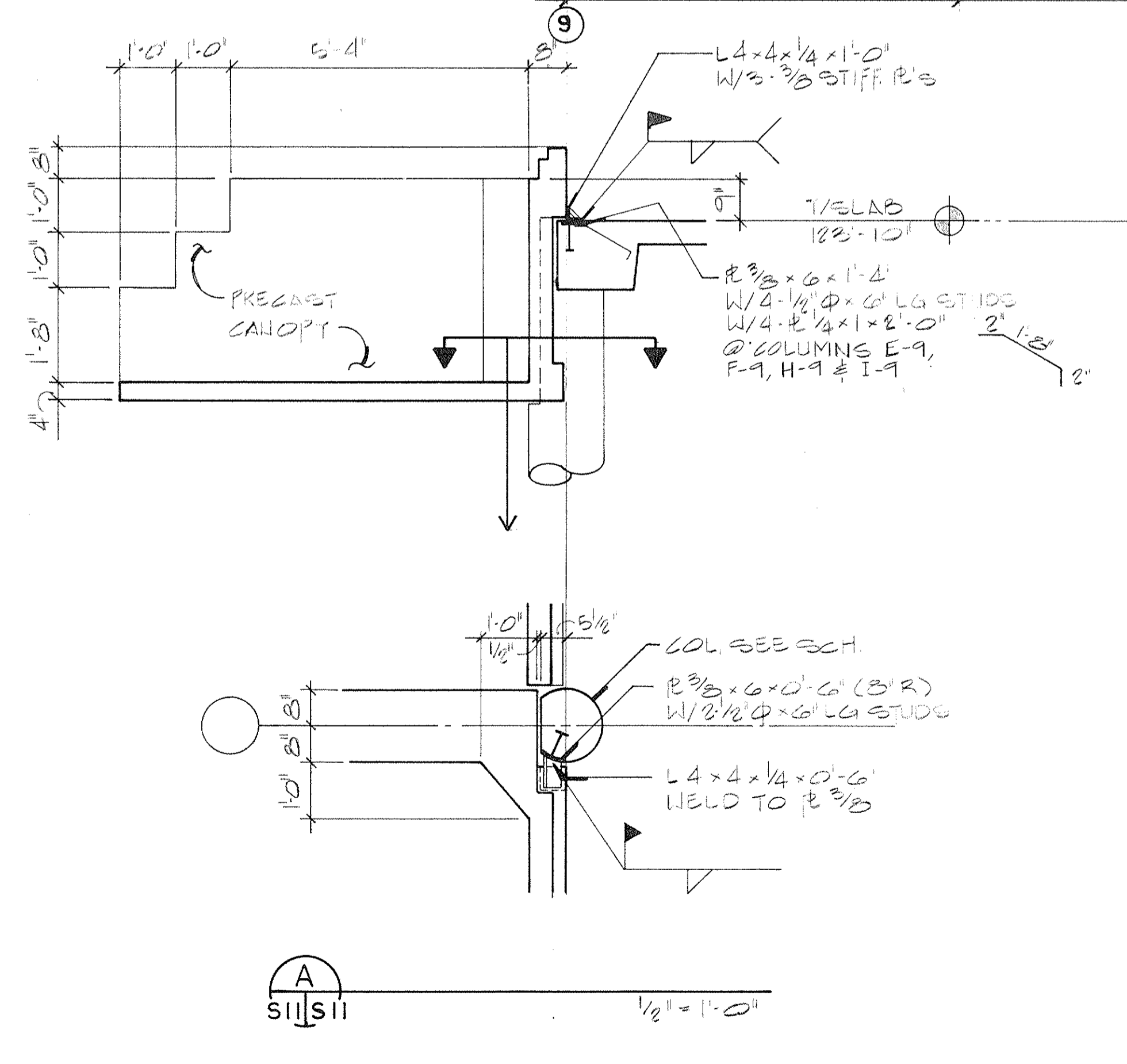
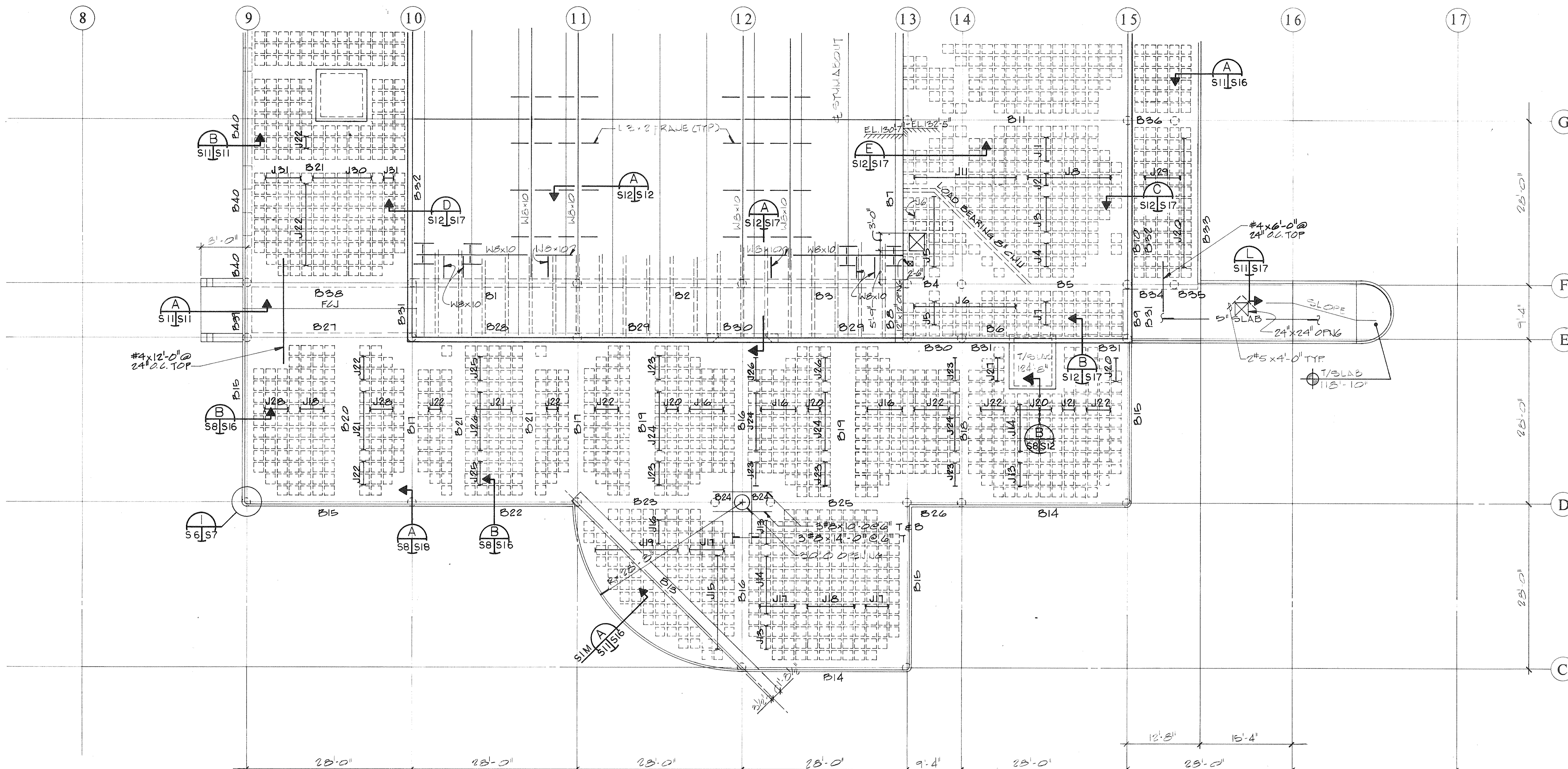

ELEV. TOP OF SLAB = 123'-10" U.O.N.

- NOTES:
- ELEV. TOP OF SLAB = 123'-10" U.O.N.
 - PRECAST CONC. WALLS TYPICAL.
 - CONC. BEAM SCHEDULE, SEE SHEET S-19.
 - CONC. JOIST SCHEDULE, SEE SHEET S-6.

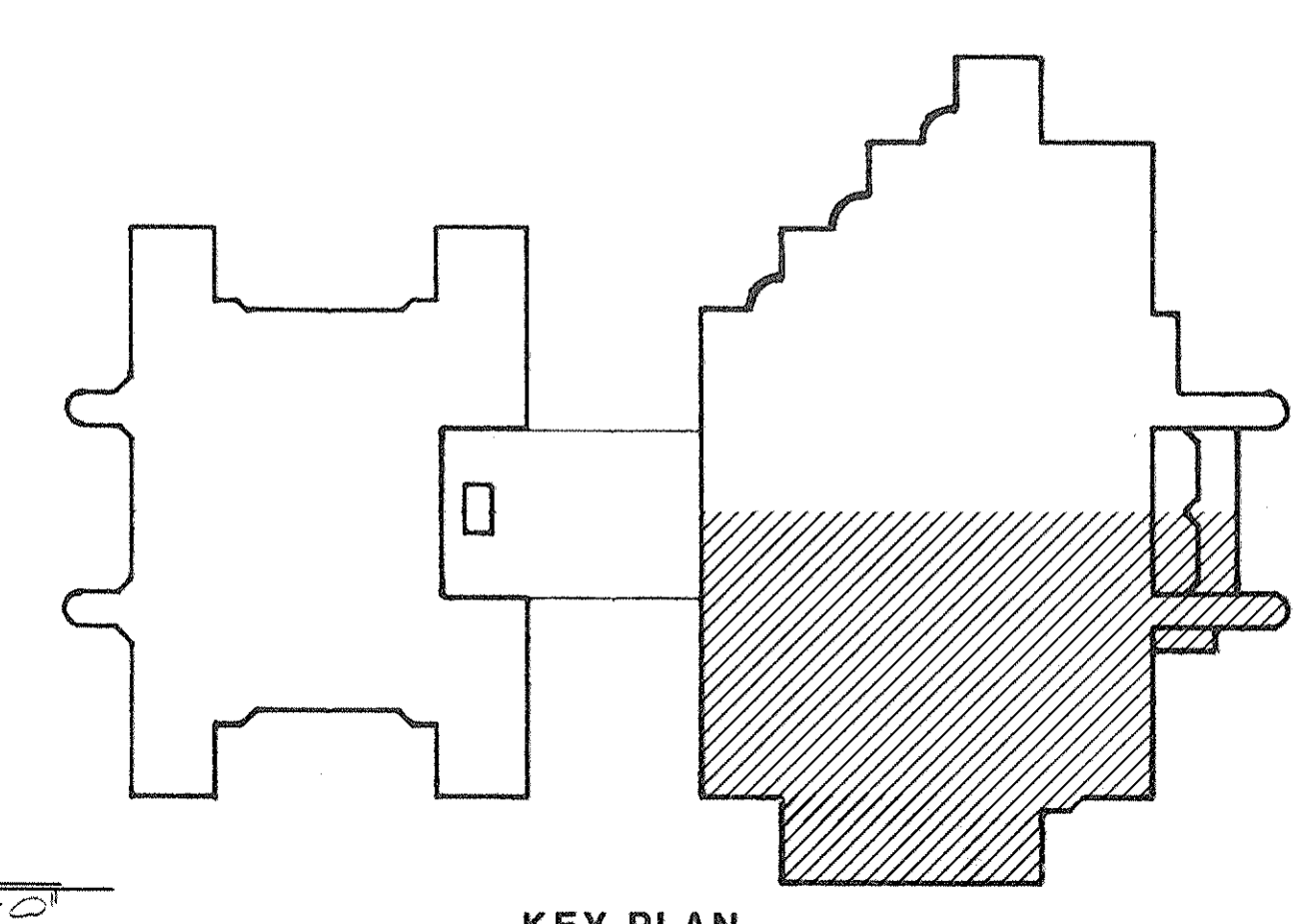

A/V MEZZANINE PLAN

ROOF FRAMING PLAN

KEY PLAN

STUDENT SERVICES "SOUTH" ROOF FRAMING PLAN

REV.	DATE	BY	CHK.
1		AIM	
2		WAG	
3		WAG	
4		RBL	
5		RBL	
6		RBL	
7		RBL	
8		RBL	
9		RBL	
10		RBL	
11		RBL	
12		RBL	
13		RBL	
14		RBL	
15		RBL	
16		RBL	
17		RBL	
18		RBL	
19		RBL	
20		RBL	
21		RBL	
22		RBL	
23		RBL	
24		RBL	
25		RBL	
26		RBL	
27		RBL	
28		RBL	
29		RBL	
30		RBL	
31		RBL	
32		RBL	
33		RBL	
34		RBL	
35		RBL	
36		RBL	
37		RBL	
38		RBL	
39		RBL	
40		RBL	
41		RBL	
42		RBL	
43		RBL	
44		RBL	
45		RBL	
46		RBL	
47		RBL	
48		RBL	
49		RBL	
50		RBL	
51		RBL	
52		RBL	
53		RBL	
54		RBL	
55		RBL	
56		RBL	
57		RBL	
58		RBL	
59		RBL	
60		RBL	
61		RBL	
62		RBL	
63		RBL	
64		RBL	
65		RBL	
66		RBL	
67		RBL	
68		RBL	
69		RBL	
70		RBL	
71		RBL	
72		RBL	
73		RBL	
74		RBL	
75		RBL	
76		RBL	
77		RBL	
78		RBL	
79		RBL	
80		RBL	
81		RBL	
82		RBL	
83		RBL	
84		RBL	
85		RBL	
86		RBL	
87		RBL	
88		RBL	
89		RBL	
90		RBL	
91		RBL	
92		RBL	
93		RBL	
94		RBL	
95		RBL	
96		RBL	
97		RBL	
98		RBL	
99		RBL	
100		RBL	

PROJECT: STUDENT SERVICES CENTER, GULF COAST COMMUNITY COLLEGE

DATE: 10-31-88

ARCHITECTS: BRIEL RHAME POYNTER & HOUSER ARCHITECTS - ENGINEERS, INC. Tallahassee, FL

ARCHITECTS: SMITH BOZARTH FULLER ARCHITECTS & PLANNERS, P.A. Panama City, FL

IBB NO 7857.02

SHEET S-11

81 OF 155

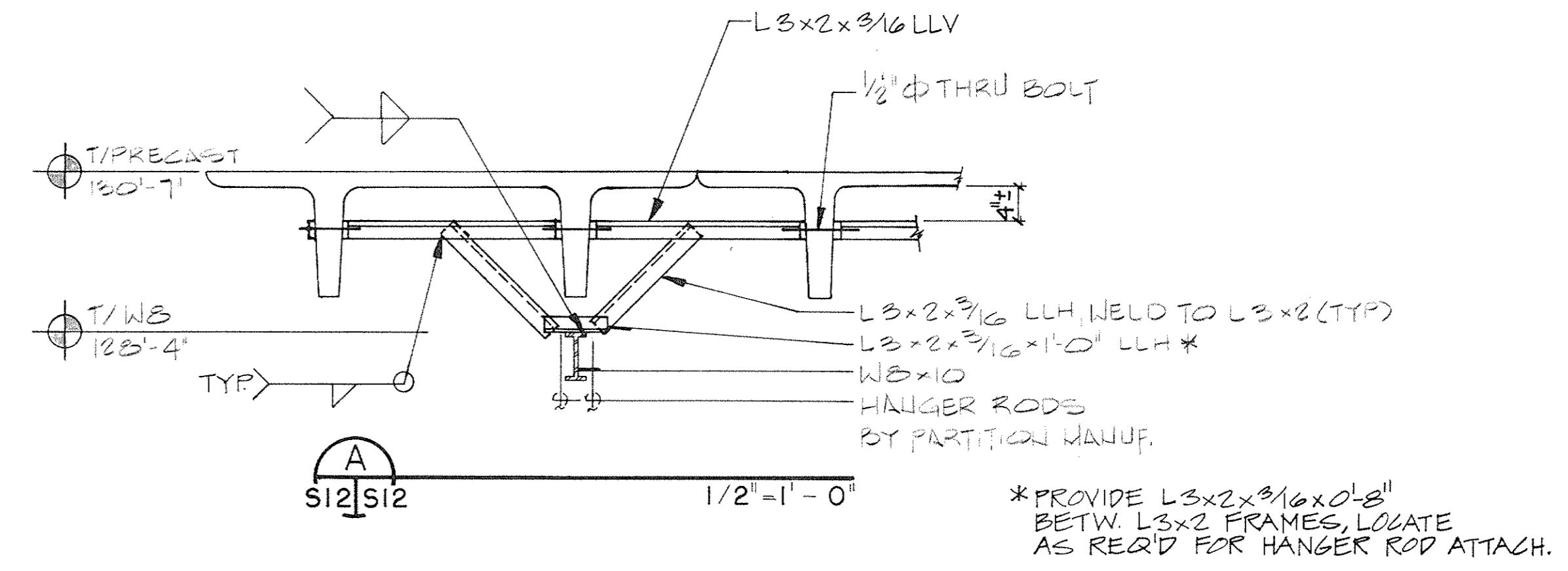
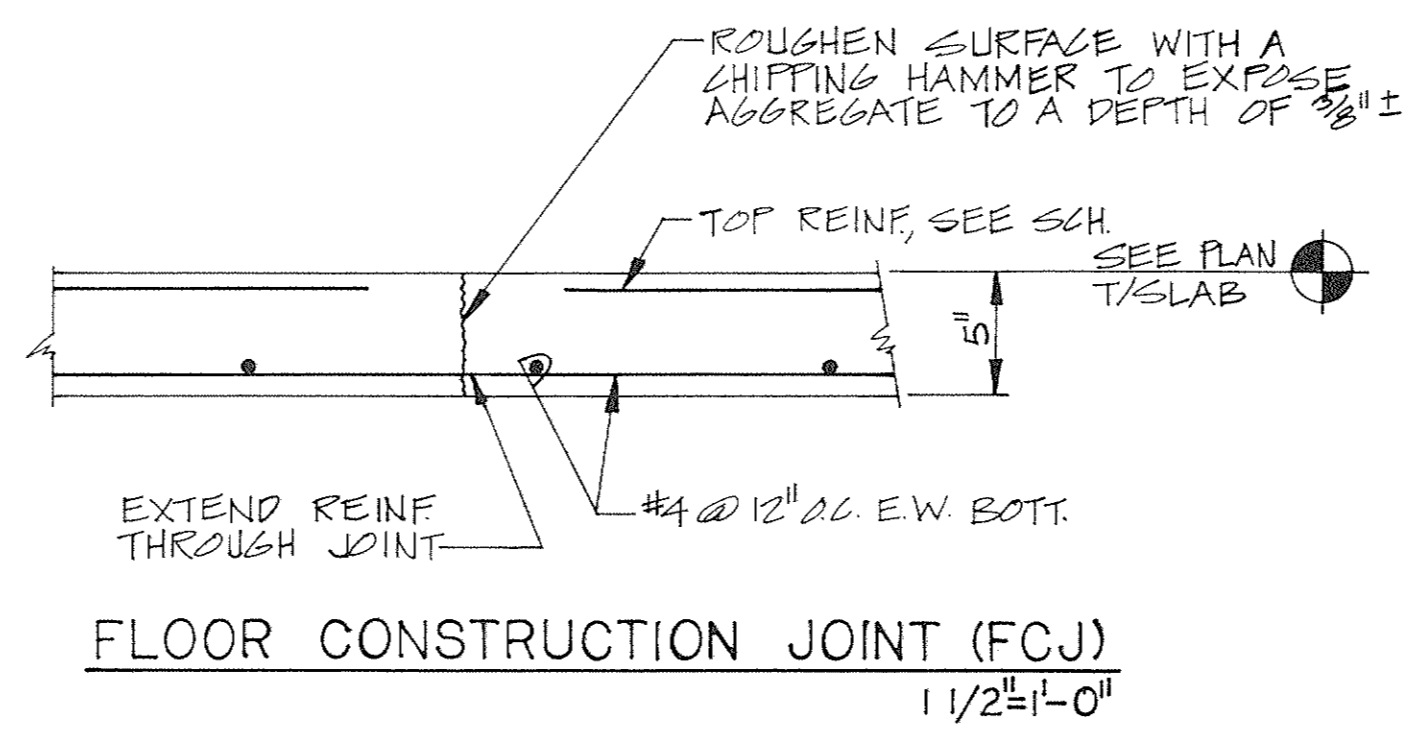
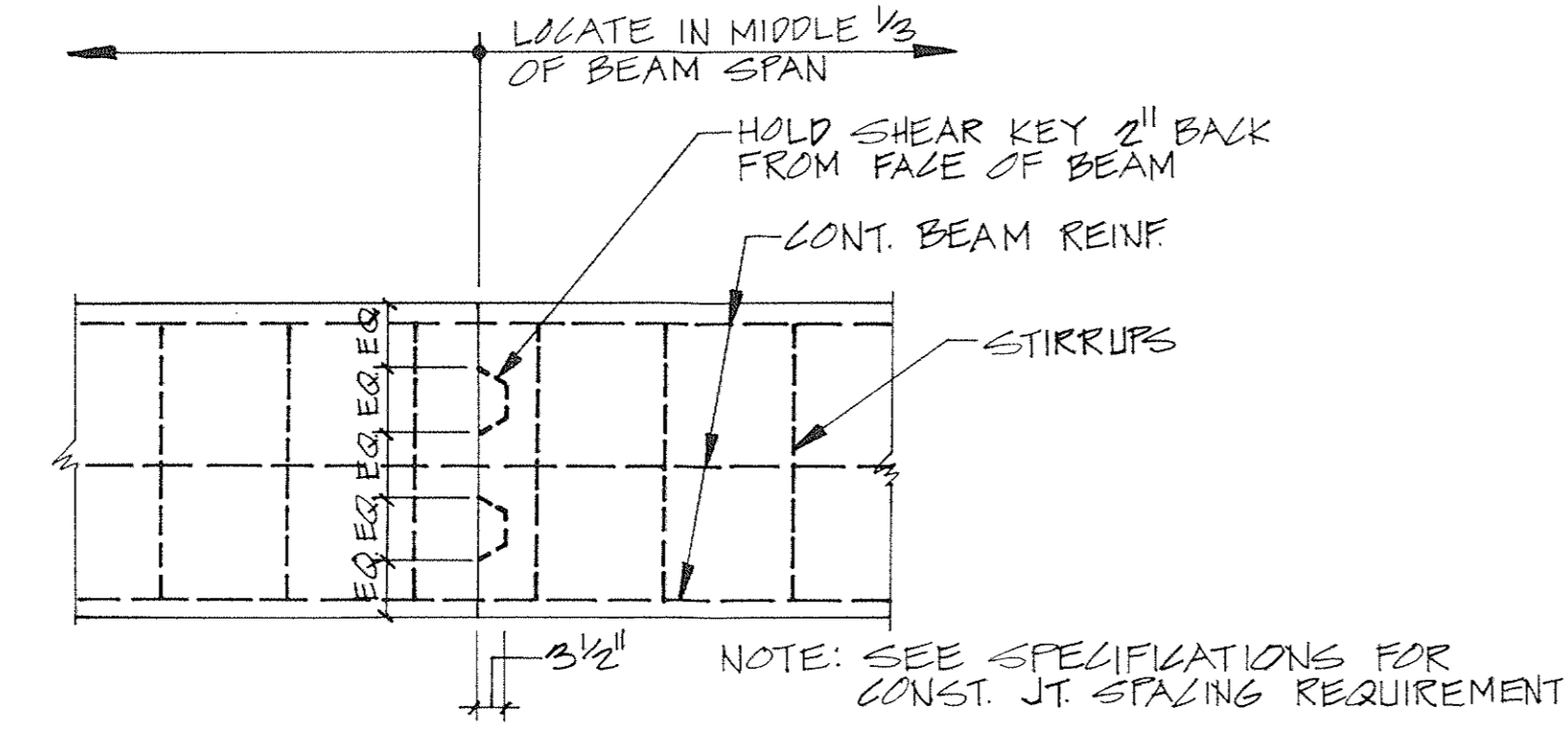
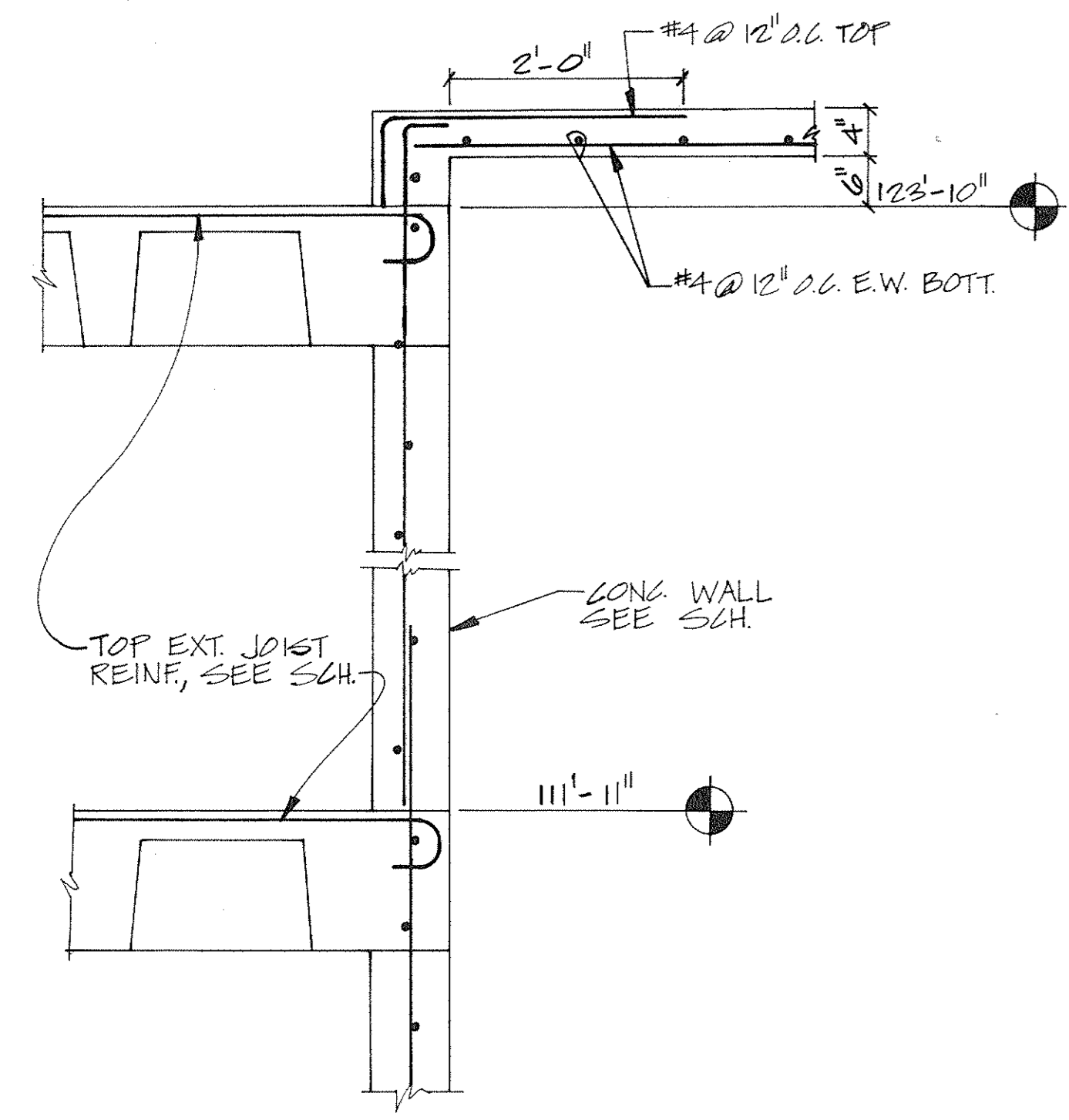

B 58/S12 3/4" = 1'-0"

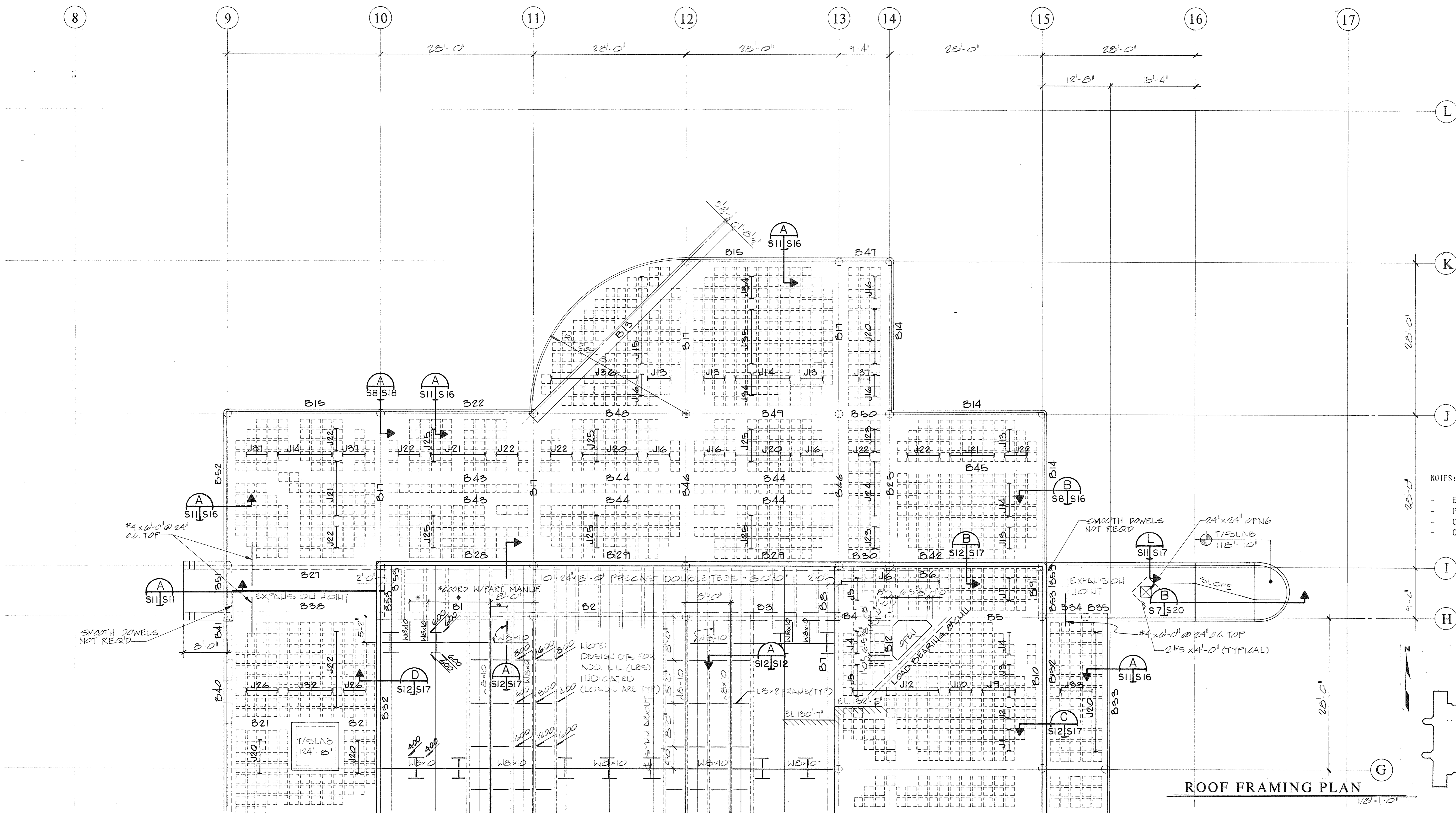

- NOTES:
- ELEV. TOP OF SLAB = 123'-10" U.O.N.
 - PRECAST CONC. WALLS TYPICAL.
 - CONC. BEAM SCHEDULE, SEE SHEET S-19.
 - CONC. JOIST SCHEDULE, SEE SHEET S-6.

ROOF FRAMING PLAN

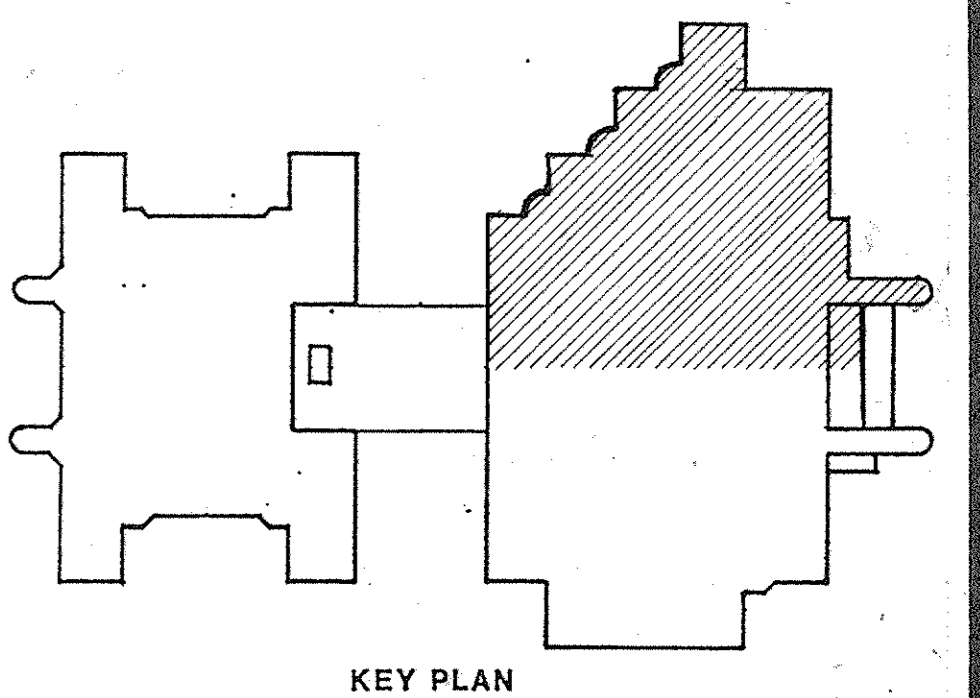

STUDENT SERVICES "NORTH" ROOF FRAMING PLAN

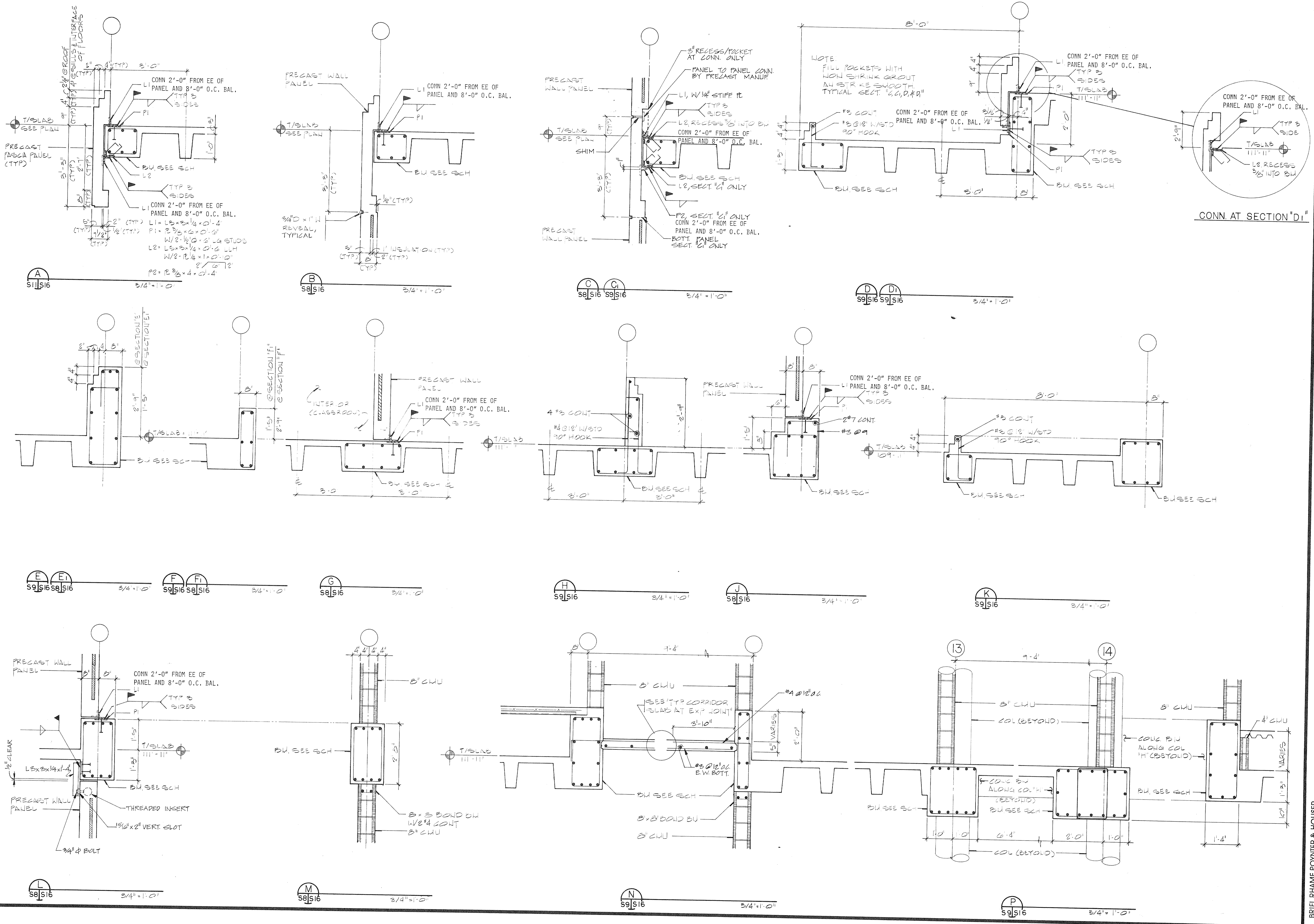

DESIGN	BY	CHK
DATE	REVISION	
NO.	DATE	
1		
2		
3		
4		
5		
6		
7		
8		
9		
10		
11		
12		
13		
14		
15		
16		

PREP: AHM
 DRAWN: MAG
 IN ASSOCIATION WITH: RFL
 CHECKED: CHD
 APPROVED: APV
 DATE: 10-31-88

STUDENT SERVICES CENTER, GULF COAST COMMUNITY COLLEGE
 PANAMA CITY, FL

BRIEL RHAME POYNTER & HOUSER
 ARCHITECTS - ENGINEERS, INC.
 TALLAHASSEE, FL
 SMITH BOZARTH FULLER
 ARCHITECTS & PLANNERS, P.A.
 PANAMA CITY, FL

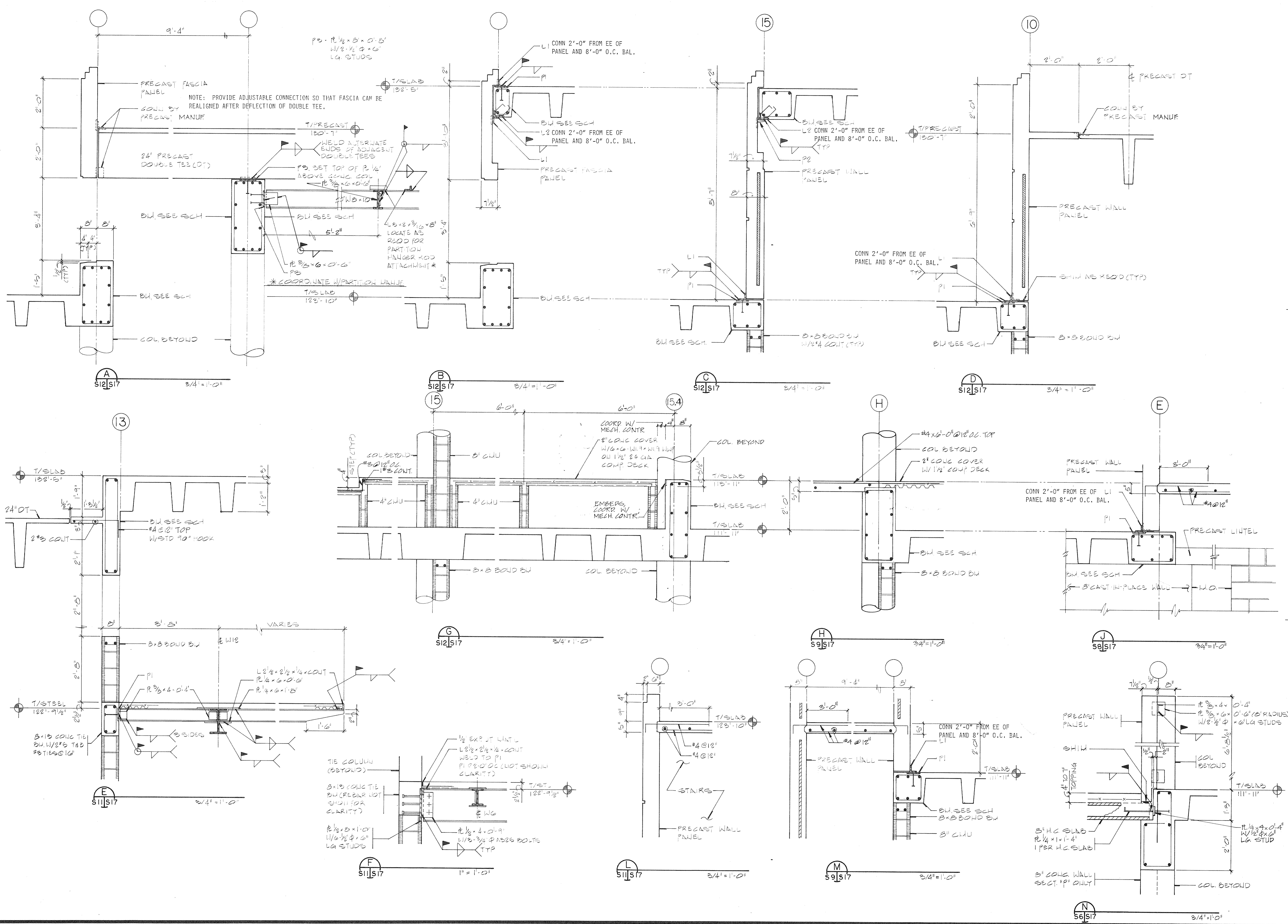

SECOND FLOOR/ROOF SECTIONS

NO.	DATE	REVISION	BY	CHK

DES: AHM
 DRAW: WAG
 IN ASSOCIATION WITH: RFL
 ARCHITECTS & PLANNERS, P.A.
 DATE: 10-31-88

STUDENT SERVICES CENTER, GULF COAST COMMUNITY COLLEGE

BRIEL RHAME POYNTER & HOUSER
 ARCHITECTS - ENGINEERS, INC.
 Tallahassee, FL
 SMITH BOZARTH FULLER
 ARCHITECTS & PLANNERS, P.A.
 Panama City, FL